



**Piezoceramics &  
Ultrasonic transducers**

**Product Catalog**

➤ Sensing and Connecting

# Table of Contents

<b>2</b>	About Us	<b>16</b>	Piezo Haptic Actuator
<b>3</b>	Certificates	<b>17</b>	Air Transducers
<b>4</b>	Core Competence & Manufacturing Capabilities	<b>18</b>	Double Feed Detection
<b>5</b>	Piezo Ceramics Material Properties	<b>20</b>	Edge Position Control (EPC)
	Material Properties for Hard and Lead Free Piezoelectric Materials	<b>22</b>	Non-contact Ultrasonic Level Detection
	Material Properties for Soft Piezoelectric Materials	<b>30</b>	Ultrasonic Gas Flow Meters
<b>6</b>	Shapes and Dimensions of the Piezoelectric Elements	<b>33</b>	Dual-frequency Non-contact Ultrasonic Level Detection
<b>7</b>	Piezo Composites	<b>35</b>	Level Detection Through Liquid
<b>11</b>	UPC Elements	<b>36</b>	Proximity Sensor
<b>12</b>	Bolt-Clamped Langevin Transducer (BLT)	<b>37</b>	Flow Meter for Liquid
<b>14</b>	Piezoelectric Bending Actuator	<b>38</b>	Product Family



# About us

## Unictron Technologies Corporation: Pioneering Excellence in Piezoceramics

Welcome to Unictron Technologies Corporation, the forefront of the piezoceramic industry. Established in 1988, we've become Taiwan's largest and most esteemed piezo manufacturer, serving satisfied customers across six continents.

Our commitment to unparalleled quality is exemplified by our adherence to RoHS, REACH, and ISO 14001 standards. With TS 16494 certification, we attest our competence in the automotive sector. Our expert team, backed by years of experience, specializes in tailoring solutions for diverse ultrasonic applications. From pioneering piezoceramics to intricate transducers, our capabilities traverse the spectrum, showcasing our dynamic competence.

By choosing Unictron, you're embracing a legacy of excellence that's continuously shaping the landscape of piezoceramics. Here, we offer a glimpse into the vast possibilities of Unictron – a world where innovation, quality, and customer-centricity converge. The future of piezoceramics is here - a realm we're pioneering.

# Certificates

## Pioneering Quality: Upholding the Highest Standards

Our commitment to delivering unparalleled quality is exemplified by the stringent standards we uphold. We don't merely follow standards; we set them. Adhering to RoHS and REACH regulations is a non-negotiable aspect of our operations. Additionally, we proudly hold the ISO 14001 certification for Hazardous Substances Management, underlining our dedication to ethical and environmentally responsible manufacturing practices. Our TS 16494 certification further attests our competence in the automotive sector.



ISO 9001:2015  
(Taoyuan Factory)



ISO 9001:2015  
(Hsinchu Factory)



ISO 14001:2015



IAFT 16949:2016  
(Taoyuan Factory)

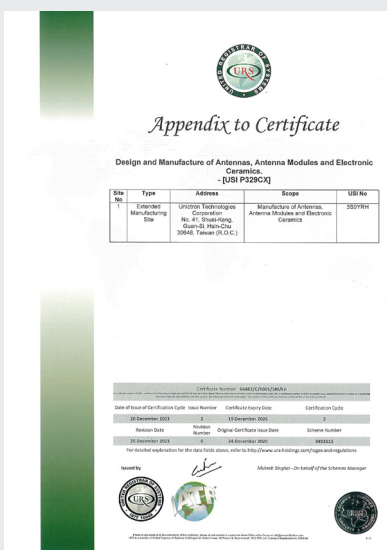

IAFT 16949:2016  
(Hsinchu Factory)



ISO 45001:2018



# Core Competence & Manufacturing Capabilities

## Facilities That Define Excellence: Where Innovation Resides

As Taiwan's foremost piezoelectric ceramics provider, Unictron offers an diverse array of products and services meticulously tailored to diverse requirements. Over three decades, our engineering teams have mastered material formulation and ceramic processing for exceptional performance. Our products span diverse dimensions, precisely aligned with your specifications. Our advanced manufacturing facilities further amplify this prowess, utilizing dry presses, cold isostatic presses, tape casters, extruders, multilayer equipment, and precision machining tools. Unictron stands as a testament to innovative precision, where formulation excellence underpins our superior manufacturing and customization capabilities.

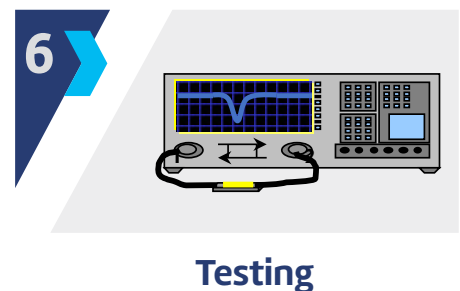
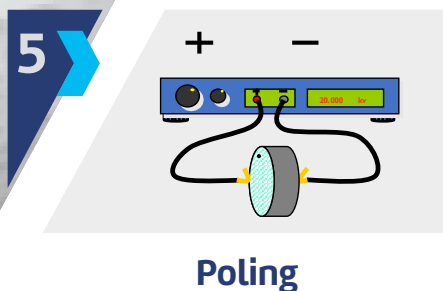
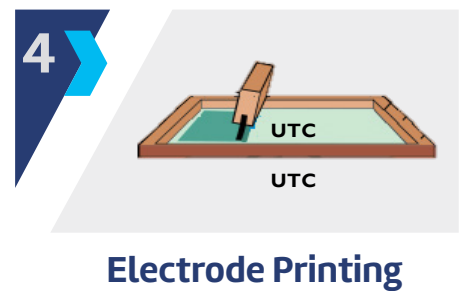
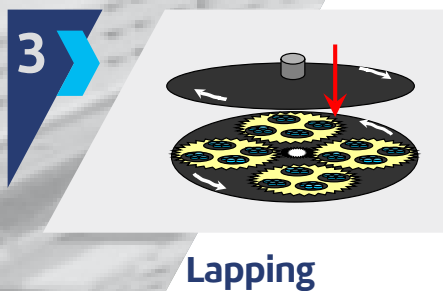
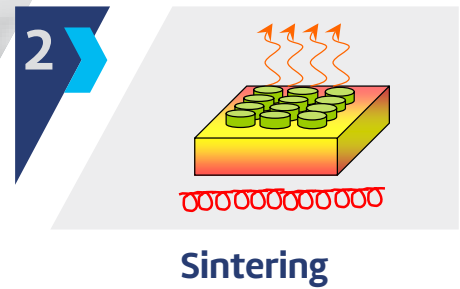
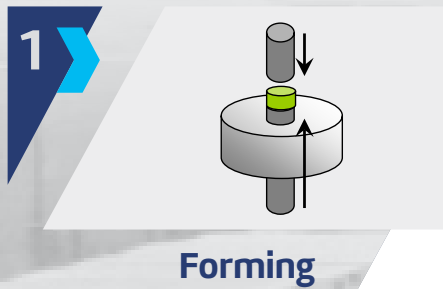

# Piezo Ceramics Material Properties

## Material Properties for Hard and Lead Free Piezoelectric Materials

Characteristics	Symbol (unit)	Hard Material Type						
		HPZT-A	HPZT-B	HPZT-C	HPZT-D	HPZT-E	PT-A	BT-A
Relative Dielectric Constant	$\epsilon_{33}/\epsilon_0$	1000	1200	1350	1550	1700	200	1200
Dissipation Factor	$\tan\delta$ (%)	0.6	0.7	0.6	0.5	0.6	1.0	0.8
Electro-mechanical Coupling Factor	$k_p$ (%)	60	58	62	63	62	2	33
	$k_{31}$ (%)	34	33	34	35	36	-	20
	$k_{33}$ (%)	68	67	68	69	71	50	49
	$k_t$ (%)	48	48	46	46	49	53	32
Mechanical Q	Qm	900	800	1300	1600	1600	700	600
Piezoelectric Constant	$d_{31}$ ( $10^{-12}\text{m/V}$ )	-120	-125	-135	-155	-160	-	-60
	$d_{33}$ ( $10^{-12}\text{m/V}$ )	250	280	300	340	350	63	150
	$g_{31}$ ( $10^{-3}\text{V}\cdot\text{m/N}$ )	-13.6	-11.8	-11.3	-11.3	-10.6	-	-5.6
	$g_{33}$ ( $10^{-3}\text{V}\cdot\text{m/N}$ )	28.2	26.4	25.1	24.8	23.3	35.6	14.1
Curie Temperature	Tc (°C)	320	310	325	300	310	260	115
Density	$\rho$ (g/cm <sup>3</sup> )	7.75	7.70	7.65	7.70	7.60	6.70	5.50
Potential Applications		Ultrasonic Generator, Sonar, Machining, Welding, Nebulizer						

## Material Properties for Soft Piezoelectric Materials

Characteristics	Symbol (unit)	Soft Material Type							
		SPZT-A	SPZT-B	SPZT-C	SPZT-D	SPZT-E	SPZT-F	SPZT-G	SPZT-H
Relative Dielectric Constant	$\epsilon_{33}/\epsilon_0$	1800	2100	2500	3000	4000	4800	5600	3650
Dissipation Factor	$\tan\delta$ (%)	1.8	2.0	2.0	2.5	2.8	2.8	3.0	2.5
Electro-mechanical Coupling Factor	$k_p$ (%)	60	68	67	68	64	64	61	65
	$k_{31}$ (%)	36	41	42	41	39	39	38	40
	$k_{33}$ (%)	70	68	70	70	71	69	69	71
	$k_t$ (%)	49	50	50	51	49	48	48	50
Mechanical Q	Qm	85	80	80	75	70	60	60	70
Piezoelectric Constant	$d_{31}$ ( $10^{-12}\text{m/V}$ )	-180	-240	-250	-280	-285	-290	-300	-280
	$d_{33}$ ( $10^{-12}\text{m/V}$ )	420	490	520	600	650	680	720	630
	$g_{31}$ ( $10^{-3}\text{V}\cdot\text{m/N}$ )	-11.3	-12.9	-11.3	-10.5	-8.0	-6.8	-6.1	-9.0
	$g_{33}$ ( $10^{-3}\text{V}\cdot\text{m/N}$ )	26.4	26.4	23.5	22.6	18.4	16.0	14.5	19.4
Curie Temperature	Tc (°C)	380	350	335	270	235	200	180	245
Density	$\rho$ (g/cm <sup>3</sup> )	7.75	7.75	7.70	7.60	7.65	7.60	7.60	7.60
Potential Applications		Flow Meter, Distance/Level Sensor, Haptic, Actuator							

\* For requests for wafer forms thinner than 0.40 mm, please contact us via [p-sales@unictron.com](mailto:p-sales@unictron.com).

\*\*Data represent typical material values. Actual production values may vary  $\pm 10\%$  for dielectric properties and  $\pm 5\%$  for electromechanical and physical properties.

\*\*\*Note: PT: Lead titanate, BT: Barium titanate

# Shapes and Dimensions of the Piezoelectric Elements

With a cumulative experience of nearly 30 years in the field, our engineering teams are masters of material formulation and ceramic processing technologies. Empowered by state-of-the-art characterization and manufacturing facilities, we excel in crafting products of diverse sizes and shapes tailored to your specific applications.



## Disc

	Bulk	Thin Plate
Diameter (mm)	3~90	3~30
Thickness (mm)	0.4~20 (depend on diameter)	0.1~0.4

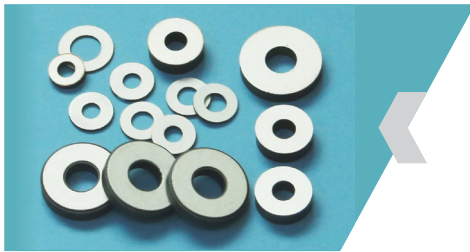

## Ring

	Bulk	Thin Plate
Outer Diameter (mm)	10~60	10~30
Inner Diameter (mm)	5~50 (depend on outer diameter)	5~20
Thickness (mm)	0.4~20	0.2~0.4



## Rectangle

	Bulk	Thin Plate
Width (mm)	1~90 (depend on length)	5~40
Length (mm)	1~208 (depend on width)	5~40
Thickness (mm)	0.4~20	0.1~0.4



## Tube

	Bulk
Outer Diameter (mm)	10~60
Inner Diameter (mm)	5~50 (depend on outer diameter)
Height (mm)	10~25



## Arc/Dome/Trapezoid

We offer customization of shapes and dimensions for Arc, Dome, Trapezoid, and more, tailored to your complex requirements

# Piezo Composites

Piezoelectric composites consist of piezoelectric ceramics, such as PZT, combined with diverse constituents like epoxy resin. This combination synergized ceramics' and polymers' strengths characterized by broad bandwidth, enabling efficacious performance across an extensive frequency spectrum. These composites boast excellent flexibility, processing capabilities, and effective acoustic impedance matching with various media such as water, air, and biological tissues.

## » Characteristics

- Lower acoustic impedances
- High coupling coefficients
- High bandwidth and lower  $Q_m$
- Excellent durability and reliability
- High power
- Tailor-made (Frequency, Electrode, Dimension, and more)

## » Applications

- High power transducer
- Hydrophone

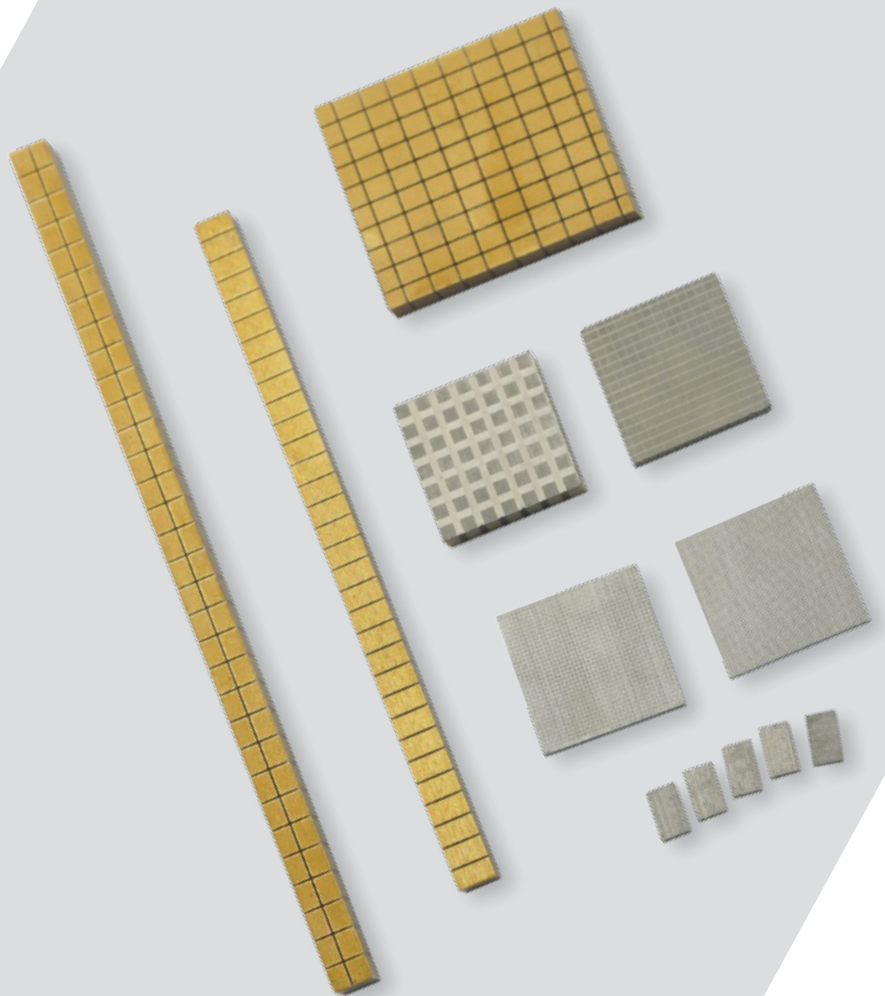

Model: GEY6  
P/N: H2KGEY62000500

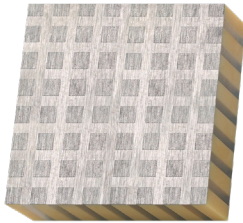

## 200kHz 1-3 Composite

### Characteristics

- Lower acoustic impedances
- High coupling coefficients
- High bandwidth and lower Qm
- Excellent durability and reliability

### Specifications

Operation Frequency	200	kHz
Capacitance at 1 kHz	600	pF
Impedance at Resonant Frequency	<270	$\Omega$
Bandwidth	>40	kHz
Electro-mechanical Coupling Coefficient (Kt)	>60	%
Maximum Operational Temperature	100	$^{\circ}\text{C}$

### Dimensions

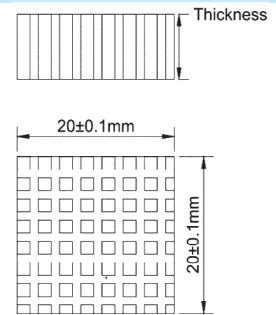

Model: GEY3  
P/N: H2KGEY35000500

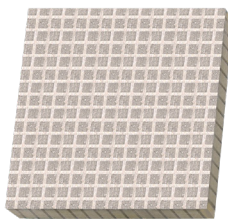

## 500kHz 1-3 Composite

### Characteristics

- Lower acoustic impedances
- High coupling coefficients
- High bandwidth and lower Qm
- Excellent durability and reliability

### Specifications

Operation Frequency	500	kHz
Capacitance at 1 kHz	1300	pF
Impedance at Resonant Frequency	<50	$\Omega$
Bandwidth	>100	kHz
Electro-mechanical Coupling Coefficient (Kt)	>60	%
Maximum Operational Temperature	100	$^{\circ}\text{C}$

### Dimensions

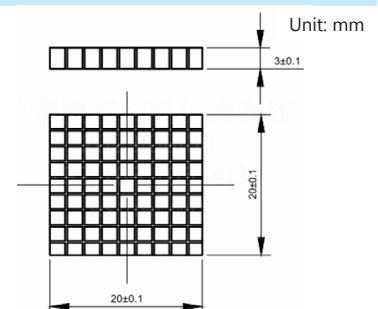



Model: GEY4  
P/N: H2KGEY41000600

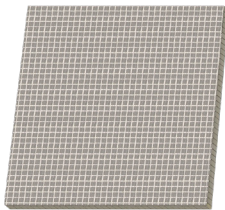

## 1000kHz 1-3 Composite

### Characteristics

- Lower acoustic impedances
- High coupling coefficients
- High bandwidth and lower Qm
- Excellent durability and reliability

### Specifications

Operation Frequency	1000	kHz
Capacitance at 1 kHz	2740	pF
Impedance at Resonant Frequency	<50	$\Omega$
Bandwidth	>200	kHz
Electro-mechanical Coupling Coefficient (Kt)	>60	%
Maximum Operational Temperature	100	$^{\circ}\text{C}$

### Dimensions

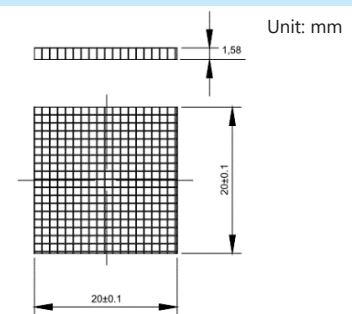

Model: GEY5  
P/N: H2KGEY52000600

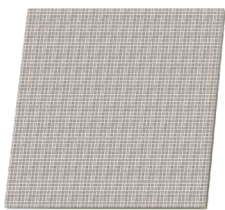

## 2000kHz 1-3 Composite

### Characteristics

- Lower acoustic impedances
- High coupling coefficients
- High bandwidth and lower Qm
- Excellent durability and reliability

### Specifications

Operation Frequency	2000	kHz
Capacitance at 1 kHz	5200	pF
Impedance at Resonant Frequency	<10	$\Omega$
Bandwidth	>420	kHz
Electro-mechanical Coupling Coefficient (Kt)	>60	%
Maximum Operational Temperature	100	$^{\circ}\text{C}$

### Dimensions

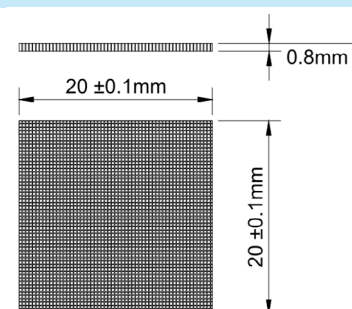

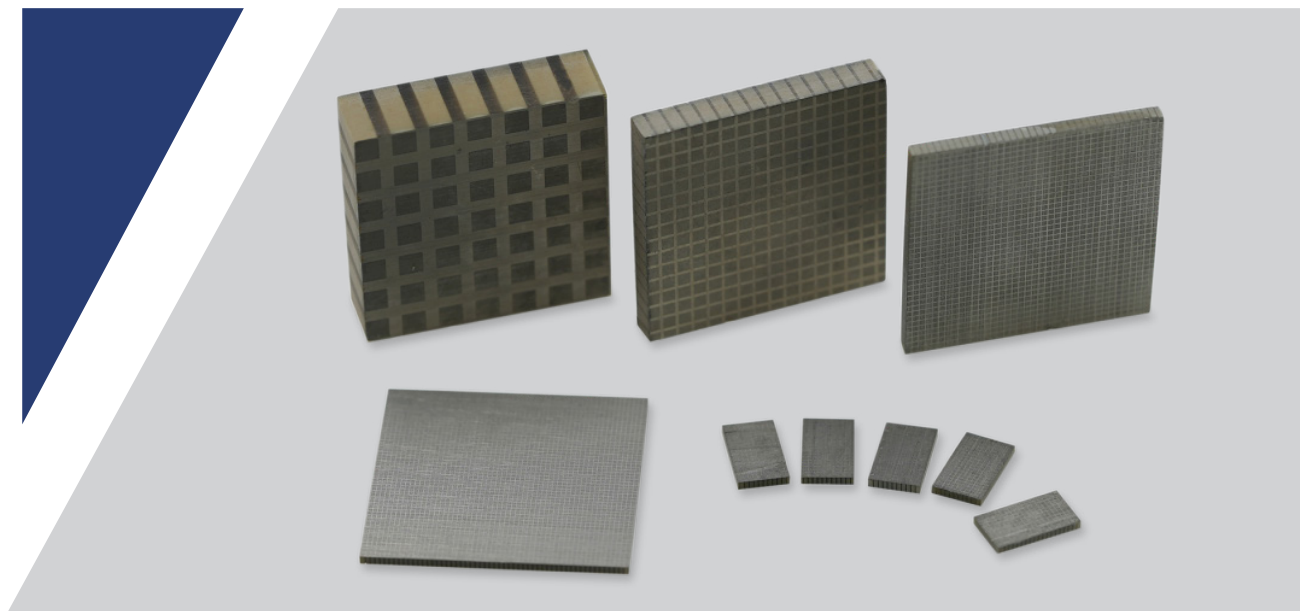

### » Table of 1–3 composite PZT

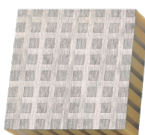
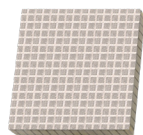
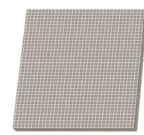
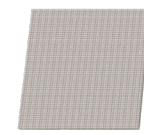
P/N		H2KGEY62000500	H2KGEY35000500	H2KGEY41000600	H2KGEY52000600
					
Operation Frequency	kHz	200	500	1000	2000
Electro-mechanical Coupling Coefficient (Kt)	%	> 60	> 60	> 60	> 60
Bandwith	kHz	> 40	> 100	> 200	> 420
Maximum Operational Temperature	°C	100	100	100	100
Electrode	-	Ni Alloy	Ni Alloy	Ni Alloy	Ni Alloy
PZT Material	-	Soft PZT	Soft PZT	Soft PZT	Soft PZT

\* Customized dimension, electrode, and frequency are available.

# UPC Elements

We proudly introduce our premier material for your underwater transducers -- Unictron's porosity controlled (UPC) elements. UPC elements are piezoceramic composites featuring a controlled porous structure within a PZT ceramic matrix. Transducers made of UPC materials show a significantly broader bandwidth that works in a precise sweep pattern of many frequencies with good efficiency and high-power output. Unictron is the largest manufacturer of porosity controlled broadband piezoceramics in the world for commercial CHIRP sonar applications.

## » Characteristics

- Work in sweeping pattern of many frequencies
- With good efficiency and high power output
- Better S/N ratio
- Better resolution
- Low Q factor
- Lower ringing



## » Applications

CHIRP (Compressed High Intensity Radar Pulse) based broadband transducer for fish finders and echo sounders.

## » Advantages of Broadband Transducer

Traditional commercial Sonar transducers operate only at one discrete frequency or dual frequencies while broadband transducers can work in sweeping pattern of multiple frequencies with excellent efficiency and high power output. This allows them to achieve better resolution and depth capability.

### Traditional

Typical bandwidth is about **5-7 KHz**

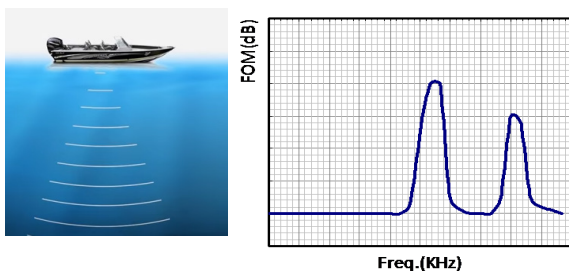

### Broadband

Typical bandwidth is about **40-60 KHz**

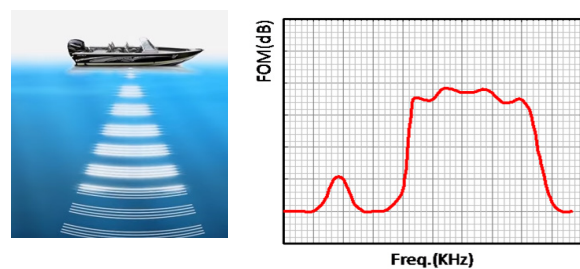

# Bolt-Clamped Langevin Transducer (BLT)

The structure of the Bolt-Clamped Langevin Transducer (BLT) ultrasonic transducer plays a crucial role in various applications, particularly in healthcare sectors. For instance, in the medical field, our BLTs find their niche in applications ranging from medical scalpels and dental scalers to atomization of specialized viscous medicine. Across industries, they're vital for cutting, cleaning, welding of plastic, metals, and specialized materials. Whether it's BLTs simulation, design, or manufacturing, Unictron stands as your dependable partner. Our BLTs can be meticulously engineered using unique in-house piezoceramic material formulations, ensuring the precise resonant frequency and amplitude required.



## » Characteristics

- High power output, high efficiency
- High quality factor, low heat generation
- Excellent frequency stability
- Excellent mechanical strength and durability

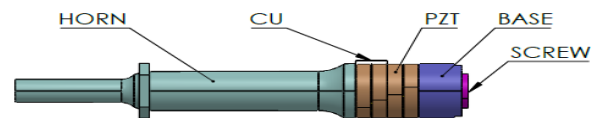

Schematic Drawing

## » Applications

Applications of BLT type Transducer:

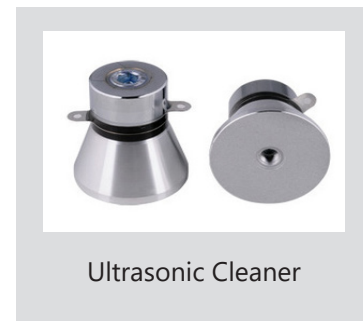
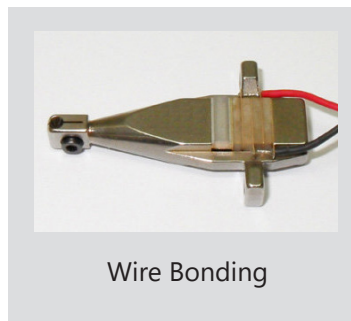

**Simulation of Transducer**

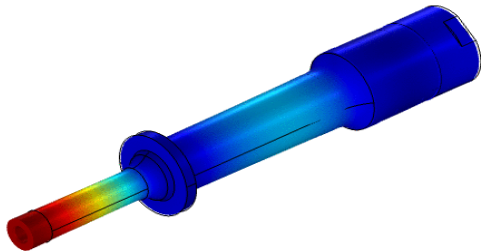

**Characteristics**

- High power output, high efficiency
- High-quality factor, low heat generation
- Excellent stability of frequency
- Excellent mechanical strength and durability

**Specifications for Ultrasonic Scalpel**

Capacitance at 1 kHz	*1	2.1 ± 20%	nF
Resonant Frequency	*1	55.5~56.3	kHz
Resonant Impedance Zr	*1	≤60	Ohm
Displacement of Horn Tip	(Power 40W)	~ 18	µm

\*1 Measured by KEYSIGNT E4990A at 25°C room temperature.

**Dental Scaler**



**Characteristics**

- Excellent stability of frequency
- High power output, high efficiency
- High-quality factor, low heat generation
- Excellent mechanical strength and durability

**Specifications for Ultrasonic Scalpel**

Capacitance at 1 kHz	*1	TBD	nF
Resonant Frequency	*1	28~45	kHz
Resonant Impedance Zr	*1	TBD	Ohm

\*1 Measured by KEYSIGNT E4990A at 25°C room temperature.



# Piezoelectric Bending Actuator

Piezoelectric actuators are electromechanical transducers that convert electrical signals into mechanical displacement and are widely used as controlling or regulating devices in modern equipment. Unictron's bending actuator is an important type of piezoelectric actuator which can produce bending movement with designated force and displacement. Actuators with either unimorph or bimorph design are available per your request.

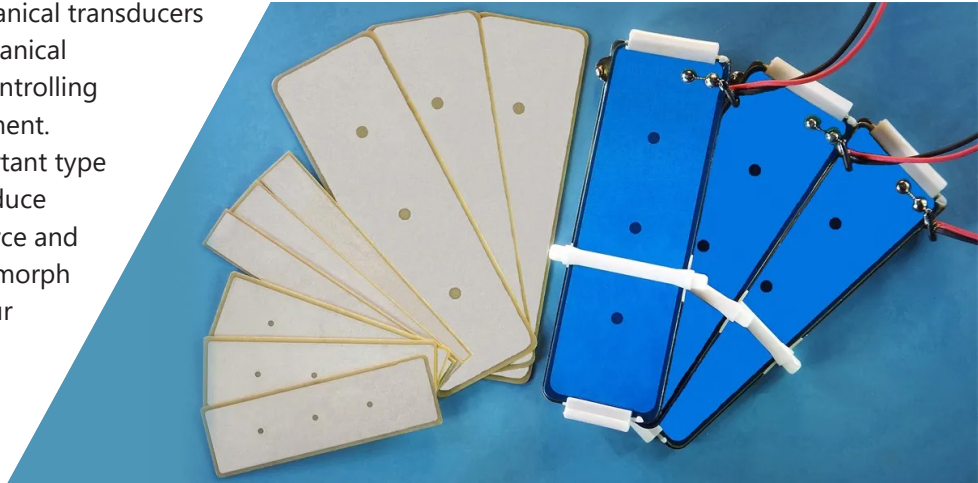

## » Characteristics

- High force output, short response time
- Low power consumption, low heat generation
- Excellent durability
- Excellent mechanical properties

## » Applications

- Actuators for needle selection in knitting machines
- Actuators of Braille displays for the visually impaired
- Controlling mechanism for valves and switches

Dimensions (mm)	Driving Voltage	Force (mN)	Displacement (mm)
64×26.3×0.56	±48V DC	Min. 320 / typical 400	Min. 0.70 / typical 0.80
64×26.3×0.56	±96V DC	Min. 320 / typical 400	Min. 0.70 / typical 0.80
40.5×12×0.63	±200V DC	Min. 400 / typical 500	Min. 0.70 / typical 0.80

Model: PPY4  
P/N: H2KPPY4000000



## Unimorph Actuator

### Characteristics

- Lightweight
- Fast response time
- Low noise
- Stable force output
- vibration modes can be changed with selected electrical signal inputs

### Specifications

Operation Frequency	50~300	Hz
Capacitance	140 ± 20%	nF
PZT Material	Soft PZT	
PZT Structure	Multilayer	
Driving Voltage	+100V~0V	V <sub>pp</sub>
Operating temperature	-40~85	°C

※ Note1: The design of the mechanism will affect the transmission of the vibration

※ Note2: The dimension can be customized

### Dimensions

Brass  $\varnothing 27\text{mm}$  Unit: mm  
Multilayer Piezo  $\varnothing 18.5\text{mm}$

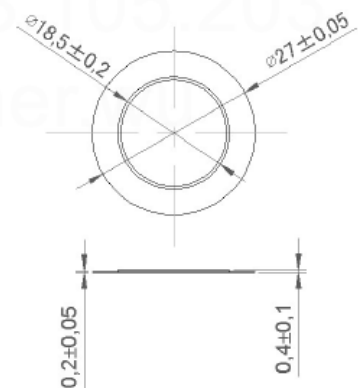

# Piezo Haptic Actuator



Piezoceramic transducers offer haptic feedback in touch displays, presenting advantages like slimness, quick response, and low power consumption. Unictron provides varied piezo elements for tailored haptic applications, available in multiple shapes, sizes, and capacitances. Our advanced facilities ensure high-performance piezoceramic elements production. These actuators are characterized by their lightness, rapid response, low noise, and stability.

## » Characteristics

- Low profile
- Fast start-up time
- Low audible noise
- Stable vibration signal
- Easy to produce various vibration modes



\* Customized sizes, shapes, thickness, and capacitances for haptic applications are available.

# Air Transducers

Ultrasonic transducers are effective tools in short-range object detection. By calculating the time difference between emitted and reflected waves (known as time of flight or ToF), these transducers easily determine the distance to detected objects.

In the realm of ultrasonic detection, a wide spectrum of objects becomes detectable. It includes solids, liquids, and powders with various surface characteristics, regardless of color, transparency, and hardness. This versatility makes ultrasonic transducers useful in various applications, such as parking sensors, level sensors, double feed detection, edge position control, flow meters, medical probes, and more.

## » Unictron Ultrasonic Air Transducers

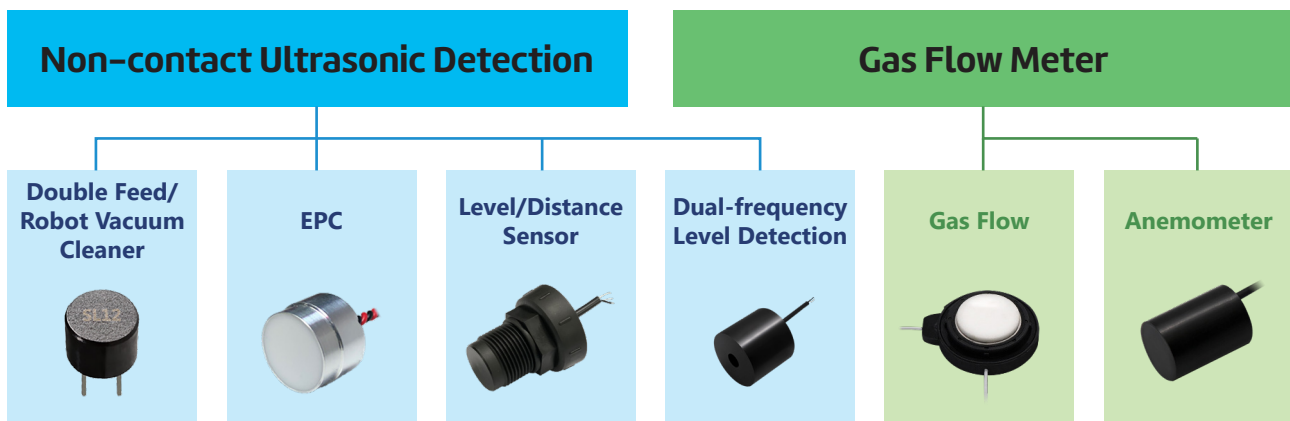

*Frequencies: from 40 kHz to 500 kHz*

## » MAIN FEATURES

### End-to-End Control

Unictron oversees the entire manufacturing process, from formulating ceramic powders to crafting piezo elements and assembling air transducers. Our meticulous supervision at each production stage allows us to finely tune the mechanical and electrical properties of the transducers.

### In-house Expertise

Leveraging our comprehensive background, we've cultivated expertise in:

- In-house production of piezoceramic elements and acoustic matching layers.
- Implementation of patented technologies.
- Achieving higher sensitivity while maintaining a tighter process output distribution.
- Ensuring exceptional reliability.

\* All specifications are subject to change without notice.

# Double Feed Detection

Ultrasound can penetrate much more through a single sheet compared with multiple sheets. It has been widely used in automatic document feeders (ADF).

Signal with a single sheet

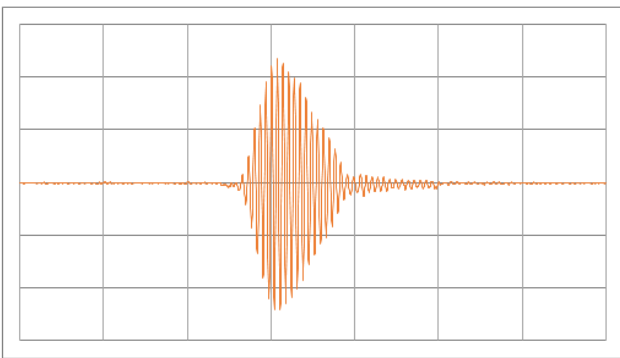

Signal with multiple sheets

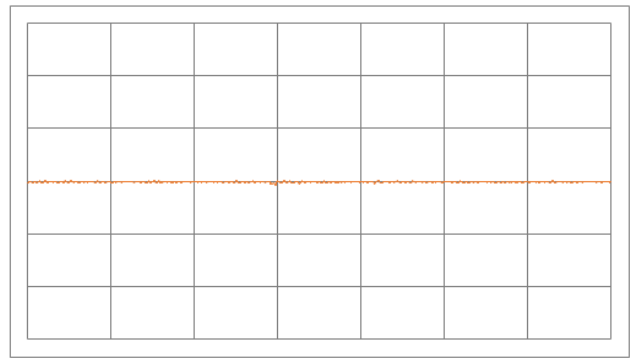

## A280A1 280 kHz Air transducer

### Major Applications

- Web guiding
- Double feed detection
- Proximity measurement

### Specifications

Operation Frequency	280 kHz
Capacitance (@ 1 kHz, 1Vrms)	1300 ± 20% pF
Directivity (Full Angle @-6 dB)	10 ± 2 degree
Maximum Sensing Range	70 cm
Blind Zone	< 3 cm
Dimension-OD	9.9 mm
Dimension-Height	7.3 mm
Housing Material	PBT
Wire	Lead

### Dimensions

Unit: mm

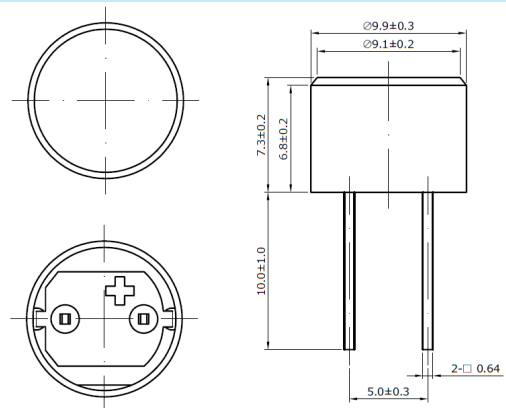

\* All specifications are subject to change without notice.





### A300A 300 kHz Air transducer

#### Major Applications

Web guiding  
 Double feed detection  
 Proximity measurement

#### Specifications

Operation Frequency	300 kHz
Capacitance (@ 1 kHz, 1Vrms)	1300 ± 20% pF
Directivity (Full Angle @-6 dB)	10 ± 2 degree
Maximum Sensing Range	60 cm
Blind Zone	< 3 cm
Dimension-OD	9.9 mm
Dimension-Height	7.3 mm
Housing Material	PBT
Wire	Lead

#### Dimensions

Unit: mm

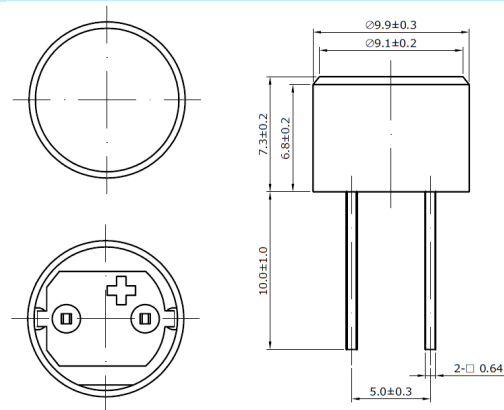

### A330A1 330 kHz Air transducer

#### Major Applications

Web guiding  
 Double feed detection  
 Proximity measurement

#### Specifications

Operation Frequency	330 kHz
Capacitance (@ 1 kHz, 1Vrms)	1300 ± 20% pF
Directivity (Full Angle @-6 dB)	10 ± 2 degree
Maximum Sensing Range	50 cm
Blind Zone	< 3 cm
Dimension-OD	9.9 mm
Dimension-Height	7.3 mm
Housing Material	PBT
Wire	Lead

#### Dimensions

Unit: mm

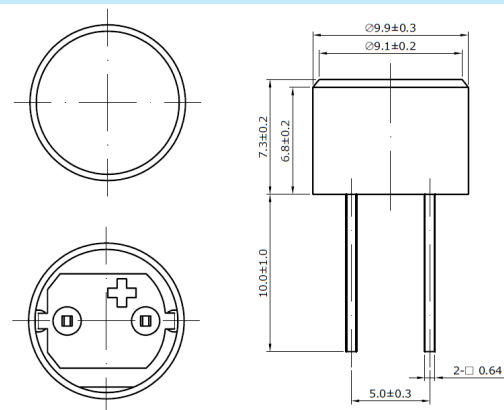

\* All specifications are subject to change without notice.

# Edge Position Control

The EPC system equipped with ultrasonic transducers is suitable for most materials, including metal or non-metal, transparent or opaque sheet, mesh or film, and any color of object, etc.

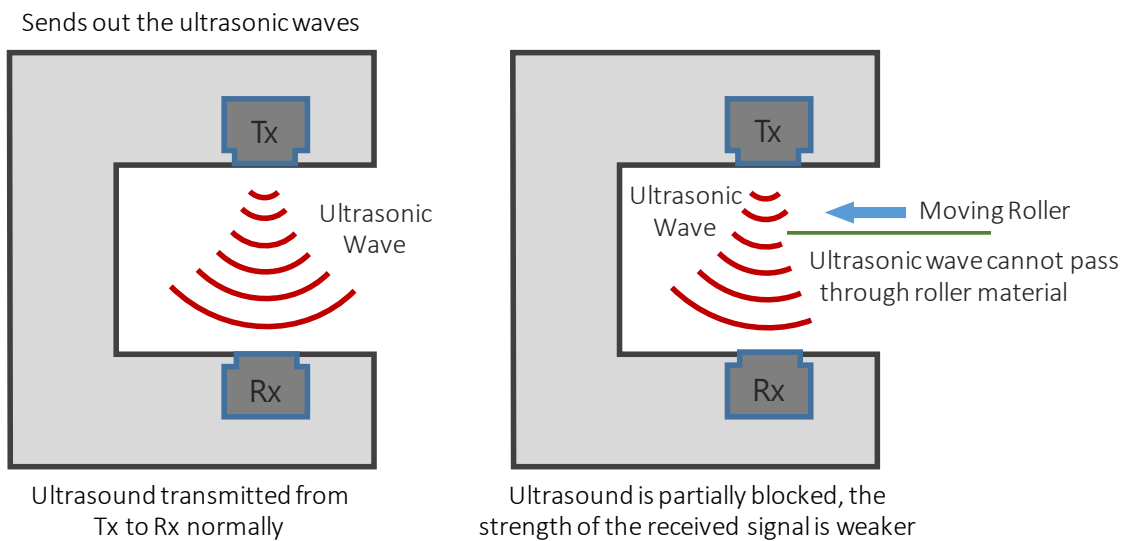

## A150A 150 kHz Air transducer

### Major Applications

Web guiding  
Proximity measurement

### Specifications

Operation Frequency	150 kHz
Capacitance (@ 1 kHz, 1Vrms)	1000 ± 20% pF
Directivity (Full Angle @-3 dB)	8 ± 2 degree
Maximum Sensing Range	250 cm
Blind Zone	< 15 cm
Dimension-OD	17.15 mm
Dimension-Height	12.70 mm
Housing Material	Aluminum
Wire	UL1430 #24AWG Ø1.43mm

### Dimensions

Unit: mm

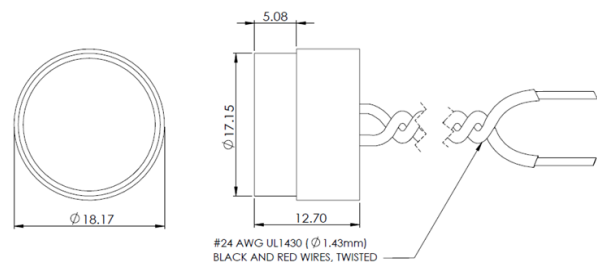

\* All specifications are subject to change without notice.



## A170W1 170 kHz Air transducer

### Major Applications

Web guiding  
Proximity measurement

Specifications	
Operation Frequency	170 kHz
Capacitance (@ 1 kHz, 1Vrms)	3000 ± 20% pF
Directivity (Full Angle @-6 dB)	X 5 ± 2 Y 25 ± 2 degree
Working Rang	> 28 mm
Dimension-Length	54.6 mm
Dimension-Width	18.2 mm
Dimension-Height	10.0 mm
Housing Material	Plastic
Wire	UL1430 #24AWG Ø1.43mm

### Dimensions

Unit: mm

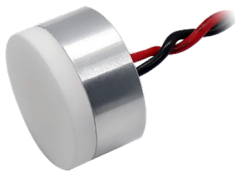
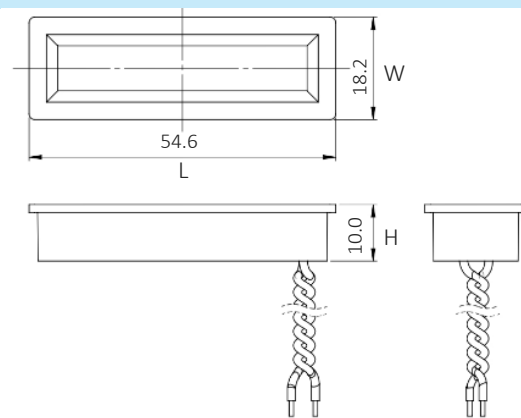

## A200H1 200 kHz Air transducer

### Major Applications

Web guiding  
Proximity measurement

Specifications	
Operation Frequency	200 kHz
Capacitance (@ 1 kHz, 1Vrms)	500 ± 20% pF
Directivity (Full Angle @-6 dB)	10 ± 2 degree
Maximum Sensing Range	200 cm
Blind Zone	< 10 cm
Dimension-OD	18.8 mm
Dimension-Height	10.7 mm
Housing Material	Aluminum
Wire	UL1430 #24AWG Ø1.43mm

### Dimensions

Unit: mm

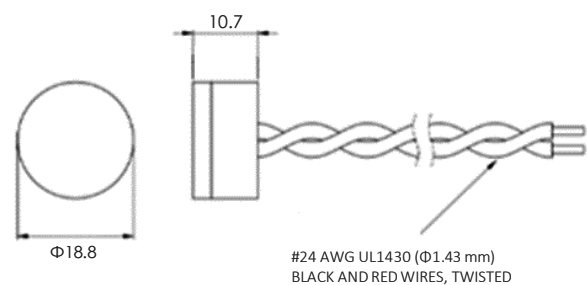

\* All specifications are subject to change without notice.

# Non-contact Ultrasonic Level Detection

Level depth can be detected with an ultrasonic transducer, acting as a transmitting and a receiving unit within one body, based on ToF calculations.

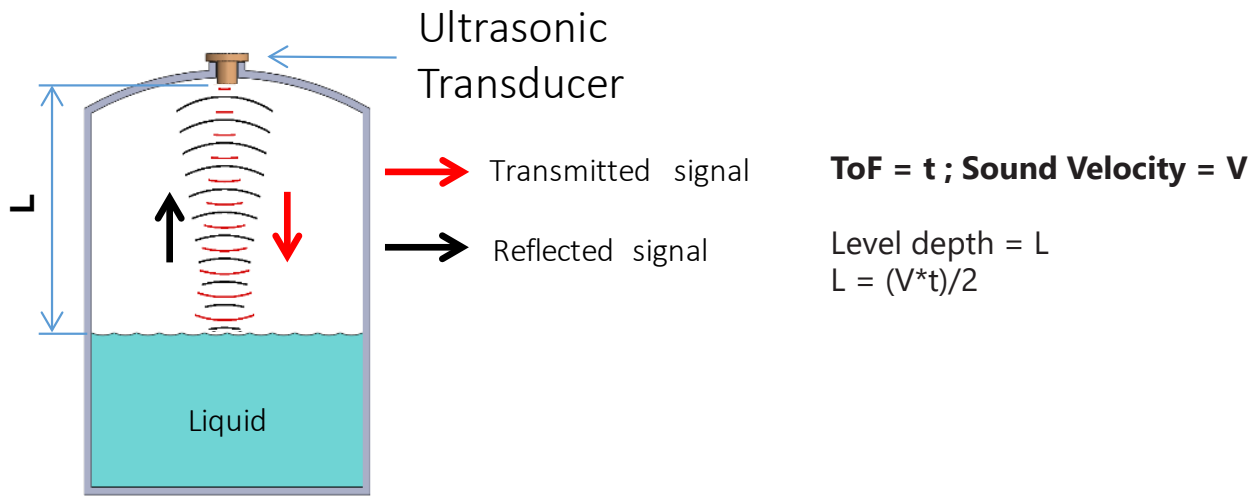

## A050A 50 kHz Air transducer

### Major Applications

- Level detection
- Proximity measurement

Specifications		Dimensions	Unit: mm
Operation Frequency	50 kHz		
Capacitance (@ 1 kHz, 1Vrms)	3500 ± 20% pF		
Directivity (Full Angle @-3 dB)	10 ± 2 degree		
Maximum Sensing Range	10 meter		
Blind Zone	< 30 cm		
Dimension-OD	47.0 mm		
Dimension-Height	48.0 mm		
Housing Material	PVDF		
Wire	RG174/U 50 ohm Ø2.7mm		

\* All specifications are subject to change without notice.



### A050B1 50 kHz Air transducer

#### Major Applications

Level detection  
Proximity measurement

Specifications	
Operation Frequency	50 kHz
Capacitance (@ 1 kHz, 1Vrms)	5000 ± 20% pF
Directivity (Full Angle @-3 dB)	10 ± 2 degree
Maximum Sensing Range	12 meter
Blind Zone	< 30 cm
Dimension-OD	56.0 mm
Dimension-Height	51.0 mm
Housing Material	PVDF
Wire	UL2464 #24AWG Ø4.0mm

#### Dimensions Unit: mm

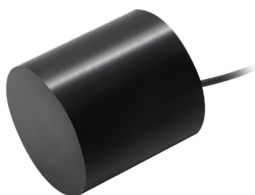
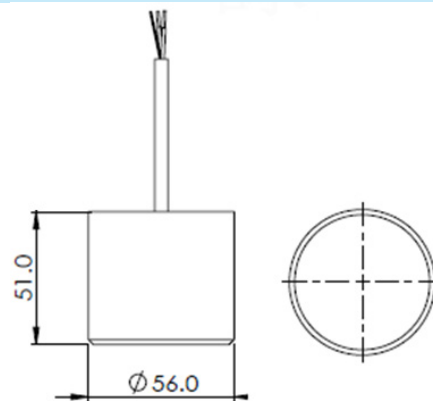

### A054L1 54 kHz Air transducer

#### Major Applications

Level detection  
Proximity measurement

Specifications	
Operation Frequency	54 kHz
Capacitance (@ 1 kHz, 1Vrms)	2600 ± 20% pF
Directivity (Full Angle @-3 dB)	10 ± 2 degree
Maximum Sensing Range	10 meter
Blind Zone	< 20 cm
Dimension-OD	47.0 mm
Dimension-Height	48.0 mm
Housing Material	PVDF
Wire	UL2464 #22AWG Ø4.0mm

#### Dimensions Unit: mm

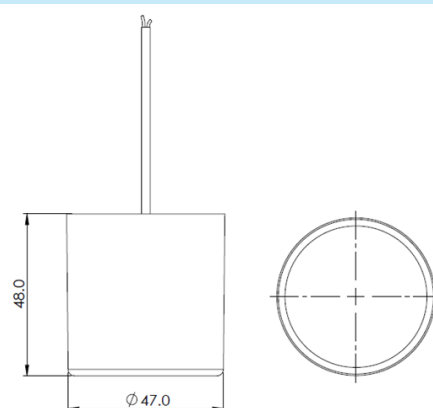

\* All specifications are subject to change without notice.



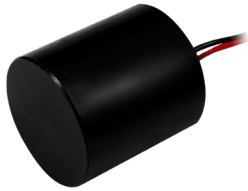

## A100A1 100 kHz Air transducer

### Major Applications

Level detection  
Proximity measurement

### Specifications

Operation Frequency	100 kHz
Capacitance (@ 1 kHz, 1Vrms)	1600 ± 20% pF
Directivity (Full Angle @-3 dB)	10 ± 2 degree
Maximum Sensing Range	4 meter
Blind Zone	< 20 cm
Dimension-OD	29.0 mm
Dimension-Height	30.0 mm
Housing Material	PVDF
Wire	UL1430 #24AWG Ø1.43mm

### Dimensions

Unit: mm

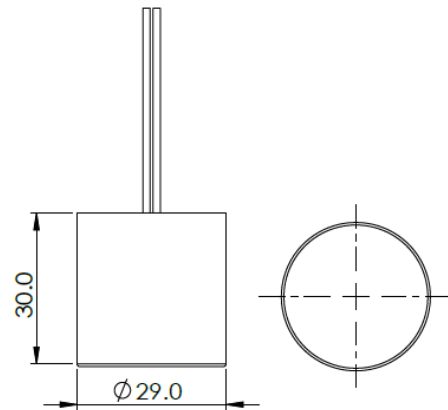

## A100C1 100 kHz Air transducer

### Major Applications

Level detection  
Proximity measurement

### Specifications

Operation Frequency	100 kHz
Capacitance (@ 1 kHz, 1Vrms)	3400 ± 20% pF
Directivity (Full Angle @-3 dB)	10 ± 2 degree
Maximum Sensing Range	4 meter
Blind Zone	< 20 cm
Dimension-OD	29.0 mm
Dimension-Height	56.1 mm
Housing Material	PVDF
Wire	UL2464 #22AWG Ø4.0mm

### Dimensions

Unit: mm

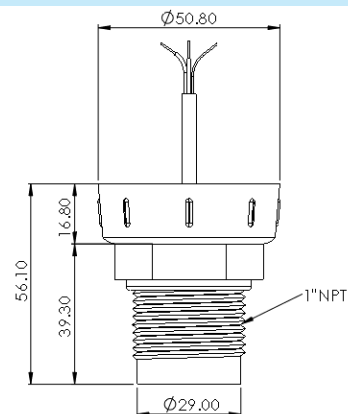

\* All specifications are subject to change without notice.

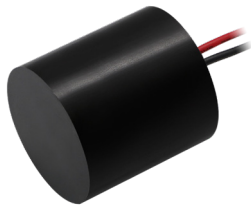

### A125A1 125 kHz Air transducer

#### Major Applications

Level detection  
Proximity measurement

Specifications	
Operation Frequency	125 kHz
Capacitance (@ 1 kHz, 1Vrms)	1000 ± 20% pF
Directivity (Full Angle @-3 dB)	10 ± 2 degree
Maximum Sensing Range	3 meter
Blind Zone	< 15 cm
Dimension-OD	25.0 mm
Dimension-Height	25.0 mm
Housing Material	PVDF
Wire	UL1430 #24AWG Ø1.43mm

#### Dimensions Unit: mm

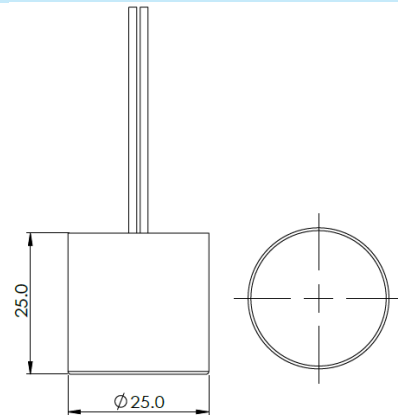

### A125E 125 kHz Air transducer

#### Major Applications

Level detection  
Proximity measurement

Specifications	
Operation Frequency	125 kHz
Capacitance (@ 1 kHz, 1Vrms)	1000 ± 20% pF
Directivity (Full Angle @-3 dB)	10 ± 2 degree
Maximum Sensing Range	3 meter
Blind Zone	< 15 cm
Dimension-OD	29.0 mm
Dimension-Height (transducer + cover)	126.6 mm
Housing Material	PVDF
Wire	UL2464 #22AWG Ø4.0mm

#### Dimensions Unit: mm

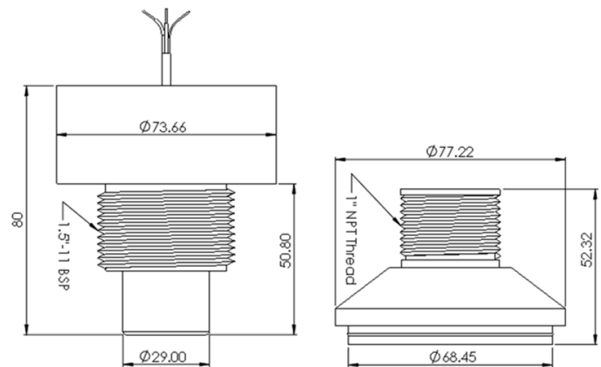

\* All specifications are subject to change without notice.



## A180M1 180 kHz Air transducer

### Major Applications

Level detection  
Proximity measurement

### Specifications

Operation Frequency	180 kHz
Capacitance (@ 1 kHz, 1Vrms)	400 ± 20% pF
Directivity (Full Angle @-3 dB)	10 ± 2 degree
Maximum Sensing Range	2 meter
Blind Zone	< 10 cm
Dimension-OD	18.2 mm
Dimension-Height	5.25 mm
Housing Material	Elastomer
Wire	UL1430 #24AWG Ø1.43mm

### Dimensions

Unit: mm

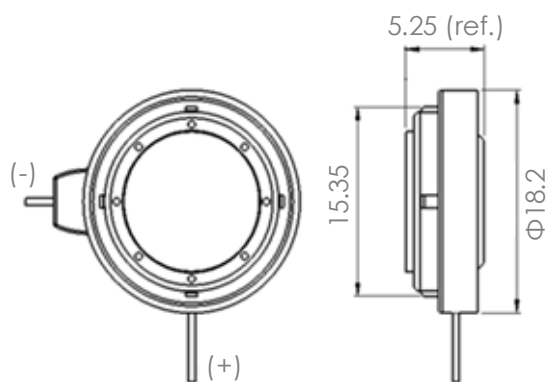

## A200A1 200 kHz Air transducer

### Major Applications

Level detection  
Proximity measurement

### Specifications

Operation Frequency	200 kHz
Capacitance (@ 1 kHz, 1Vrms)	500 ± 20% pF
Directivity (Full Angle @-3 dB)	8 ± 2 degree
Maximum Sensing Range	2 meter
Blind Zone	< 5 cm
Dimension-OD	16.0 mm
Dimension-Height	19.0 mm
Housing Material	PVDF
Wire	UL1430 #24AWG Ø1.43mm

### Dimensions

Unit: mm

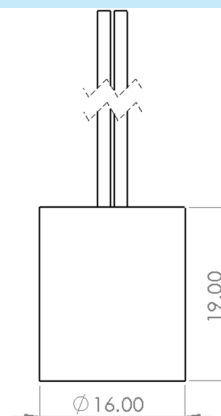

\* All specifications are subject to change without notice.

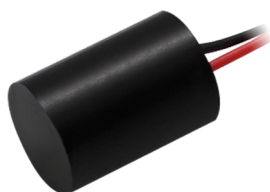

## A240A1 240 kHz Air transducer

### Major Applications

Level detection  
Proximity measurement

Specifications	
Operation Frequency	240 kHz
Capacitance (@ 1 kHz, 1Vrms)	400 ± 20% pF
Directivity (Full Angle @-3 dB)	8 ± 2 degree
Maximum Sensing Range	1.2 meter
Blind Zone	< 4 cm
Dimension-OD	13.5 mm
Dimension-Height	18.5 mm
Housing Material	PVDF
Wire	UL1430 #24AWG Ø1.43mm

### Dimensions Unit: mm

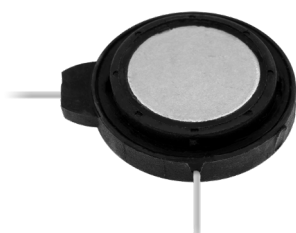
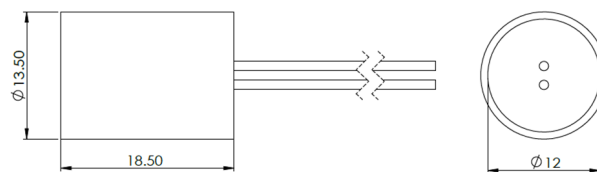

## A250M1 250 kHz Air transducer

### Major Applications

Level detection  
Proximity measurement

Specifications	
Operation Frequency	250 kHz
Capacitance (@ 1 kHz, 1Vrms)	400 ± 20% pF
Directivity (Full Angle @-3 dB)	8 ± 2 degree
Maximum Sensing Range	1 meter
Blind Zone	< 5 cm
Dimension-OD	18.2 mm
Dimension-Height	5.25 mm
Housing Material	Elastomer
Wire	UL1430 #24AWG Ø1.43mm

### Dimensions Unit: mm

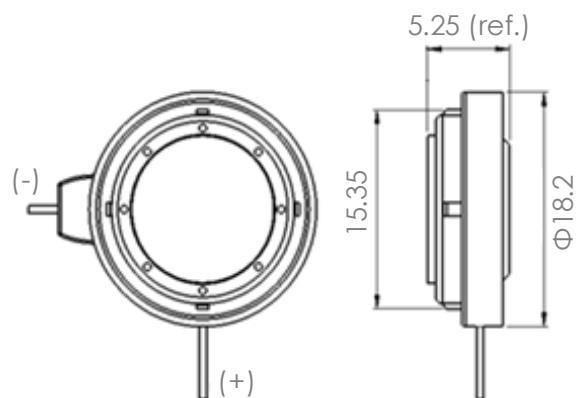

\* All specifications are subject to change without notice.

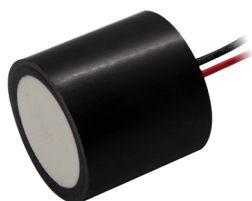

### A100F1 100 kHz Air transducer

#### Major Applications

Level detection  
Proximity measurement

Specifications	
Operation Frequency	100 kHz
Capacitance (@ 1 kHz, 1Vrms)	1600 ± 20% pF
Directivity (Full Angle @-3 dB)	10 ± 2 degree
Maximum Sensing Range	4 meter
Blind Zone	< 20 cm
Dimension-OD	29.0 mm
Dimension-Height	28.5 mm
Housing Material	PVDF
Wire	UL1430 #24AWG Ø1.43mm

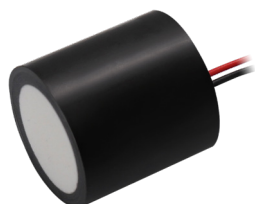
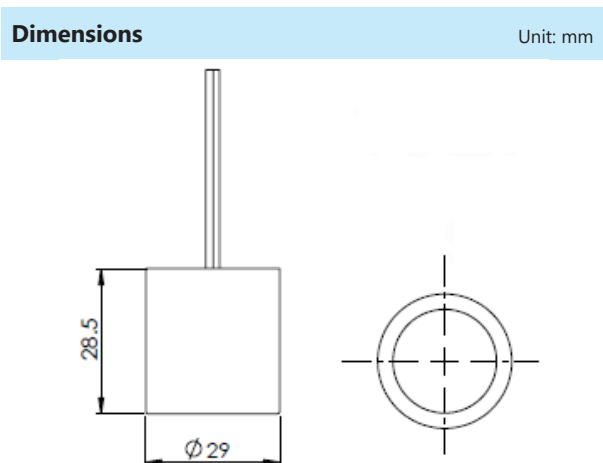

### A125F1 125 kHz Air transducer

#### Major Applications

Level detection  
Proximity measurement

Specifications	
Operation Frequency	125 kHz
Capacitance (@ 1 kHz, 1Vrms)	1000 ± 20% pF
Directivity (Full Angle @-3 dB)	10 ± 2 degree
Maximum Sensing Range	3 meter
Blind Zone	< 15 cm
Dimension-OD	25.0 mm
Dimension-Height	23.5 mm
Housing Material	PVDF
Wire	UL1430 #24AWG Ø1.43mm

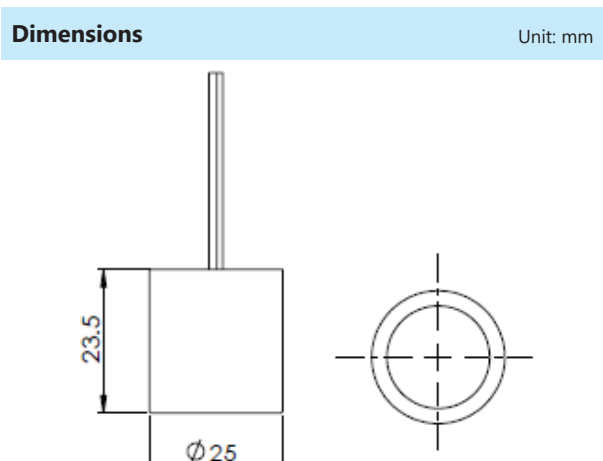

\* All specifications are subject to change without notice.



### A200F1 200 kHz Air transducer

#### Major Applications

Level detection  
Proximity measurement

Specifications	
Operation Frequency	200 kHz
Capacitance (@ 1 kHz, 1Vrms)	500 ± 20% pF
Directivity (Full Angle @-3 dB)	8 ± 2 degree
Maximum Sensing Range	2 meter
Blind Zone	< 5 cm
Dimension-OD	16.0 mm
Dimension-Height	18.0 mm
Housing Material	PVDF
Wire	UL1430 #24AWG Ø1.43mm

#### Dimensions Unit: mm

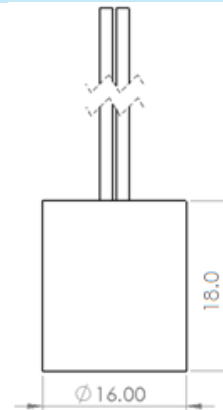

### A240F1 240 kHz Air transducer

#### Major Applications

Level detection  
Proximity measurement

Specifications	
Operation Frequency	240 kHz
Capacitance (@ 1 kHz, 1Vrms)	400 ± 20% pF
Directivity (Full Angle @-3 dB)	8 ± 2 degree
Maximum Sensing Range	1.2 meter
Blind Zone	< 4 cm
Dimension-OD	13.5 mm
Dimension-Height	17.5 mm
Housing Material	PVDF
Wire	UL1430 #24AWG Ø1.43mm

#### Dimensions Unit: mm

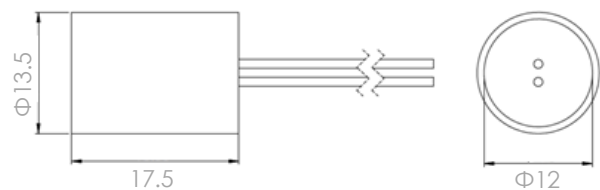

\* All specifications are subject to change without notice.

# Ultrasonic Gas Flow Meter

Gas flow rate can be detected using a pair of ultrasonic transducers, based on ToF difference between upstream and downstream directions.

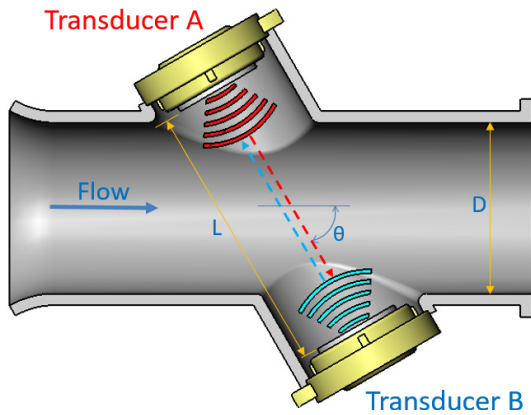

$$V = L/2\cos\theta [ 1/T_{AB} - 1/T_{BA} ]$$

V = Gas flow rate

T<sub>AB</sub>: downstream ToF

T<sub>BA</sub>: upstream ToF



## A200D1 200 kHz Air transducer

### Major Applications

Gas flow meter

### Specifications

Operation Frequency	200 kHz
Capacitance (@ 1 kHz, 1Vrms)	500 ± 20% pF
Directivity (Full Angle @-3 dB)	8 ± 2 degree
Dimension-OD	16.0 mm
Dimension-Height	19.0 mm
ZFD (Zero Flow Drift)	< 1.0 ns
Housing Material	PVDF
Operating Temperature	-25°C to +55°C
Storage Temperature	-40°C to +85°C

### Dimensions

Unit: mm

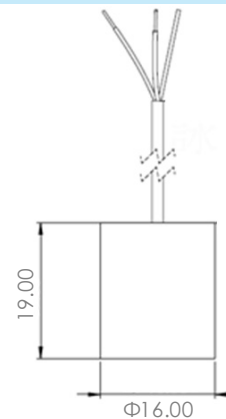

\* All specifications are subject to change without notice.





## A200M5 200 kHz Air transducer

### Major Applications

Gas flow meter  
Proximity measurement

### Specifications

Operation Frequency	200 kHz
Capacitance (@ 1 kHz, 1Vrms)	350 ± 20% pF
Directivity (Full Angle @-3 dB)	9 ± 2 degree
Dimension-OD	18.2 mm
Dimension-Height	8.5 (ref.) mm
ZFD (Zero Flow Drift)	< 1.0 ns
Housing Material	Elastomer
Operating Temperature	-25°C to +55°C
Storage Temperature	-40°C to +85°C

### Dimensions

Unit: mm

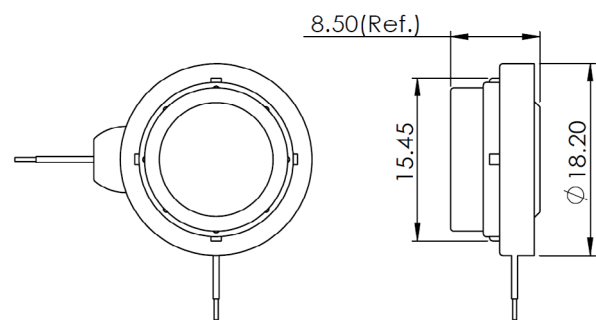

## A240B1 240 kHz Air transducer

### Major Applications

Anemometer  
Gas flow meter

### Specifications

Operation Frequency	240 kHz
Capacitance (@ 1 kHz, 1Vrms)	400 ± 20% pF
Directivity (Full Angle @-3 dB)	8 ± 2 degree
Dimension-OD	13.5 mm
Dimension-Height	18.5 mm
ZFD (Zero Flow Drift)	< 1.0 ns
Housing Material	PVDF
Operating Temperature	-30°C to +60°C
Storage Temperature	-40°C to +85°C

### Dimensions

Unit: mm

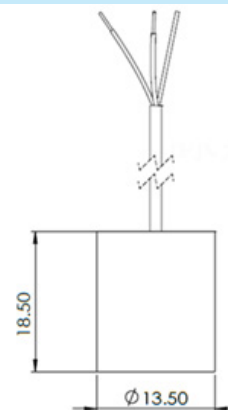

\* All specifications are subject to change without notice.



### A240M3 240 kHz Air transducer

#### Major Applications

Gas flow meter  
Proximity measurement

#### Specifications

Operation Frequency	240 kHz
Capacitance (@ 1 kHz, 1Vrms)	400 ± 20% pF
Directivity (Full Angle @-3 dB)	10 ± 2 degree
Dimension-OD	18.2 mm
Dimension-Height	7.0 (ref.) mm
ZFD (Zero Flow Drift)	< 1.0 ns
Housing Material	Elastomer
Operating Temperature	-25°C to +55°C
Storage Temperature	-40°C to +85°C

#### Dimensions

Unit: mm

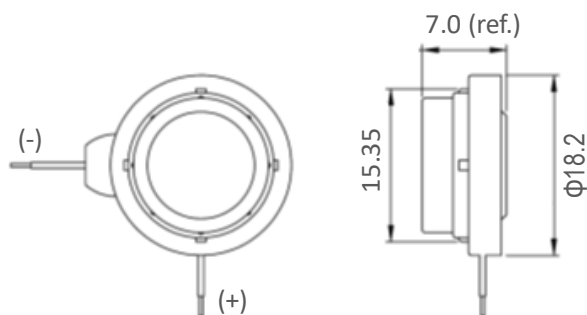

### A500B1 500 kHz Air transducer

#### Major Applications

Gas flow meter  
Proximity measurement

#### Specifications

Operation Frequency	500 kHz
Capacitance (@ 1 kHz, 1Vrms)	320 ± 20% pF
Directivity (Full Angle @-3 dB)	7 ± 2 degree
Dimension-OD	18.2 mm
Dimension-Height	6.35 (ref.) mm
ZFD (Zero Flow Drift)	< 1.0 ns
Housing Material	Elastomer
Operating Temperature	-25°C to +55°C
Storage Temperature	-40°C to +85°C

#### Dimensions

Unit: mm

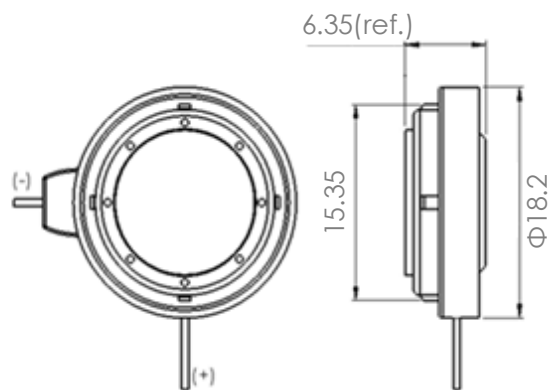

\* All specifications are subject to change without notice.

# Dual-frequency Non-contact Ultrasonic Level Detection

Unictron has successfully developed a novel type of dual-frequency non-contact ultrasonic air transducer with innovative technologies. This provides the advantage of maximizing detection distance and minimizing the blind zone in one transducer, making the application of the transducer more flexible.

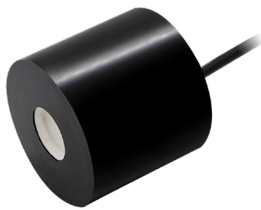
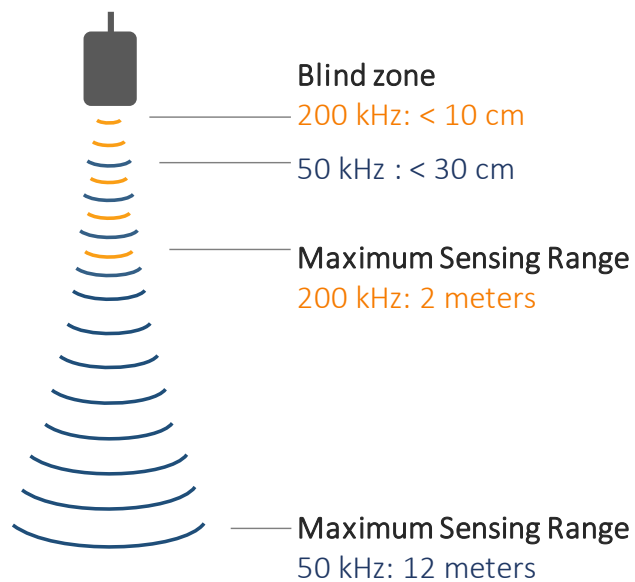

## Y050A1 50/200 kHz Air transducer

### Major Applications

Level detection  
Proximity measurement

Specifications		Dimensions		Unit: mm
	50 kHz	200 kHz		
Operation Frequency	50	200	kHz	
Capacitance (@ 1 kHz, 1Vrms)	1500 ± 20%		pF	
Directivity (Full Angle @-3 dB)	10 ± 2	6 ± 2	degree	
Maximum Sensing Range	12	2	meter	
Blind Zone	< 30	< 10	cm	
Housing Material	PVDF			

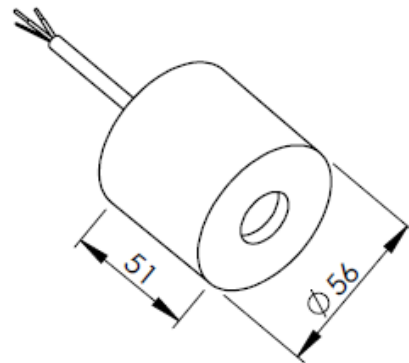

\* All specifications are subject to change without notice.



## Y050T1 50/200 kHz Air transducer

### Major Applications

Level detection  
Proximity measurement

Specifications		Dimensions		Unit: mm
	50 kHz	200 kHz		
Operation Frequency	50	200	kHz	
Capacitance (@ 1 kHz, 1Vrms)	1500 ± 20%		pF	
Directivity (Full Angle @-3 dB)	10 ± 2	6 ± 2	degree	
Maximum Sensing Range	12	2	meter	
Blind Zone	< 30	< 10	cm	
Housing Material	PVDF			

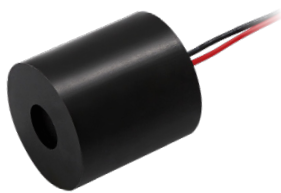
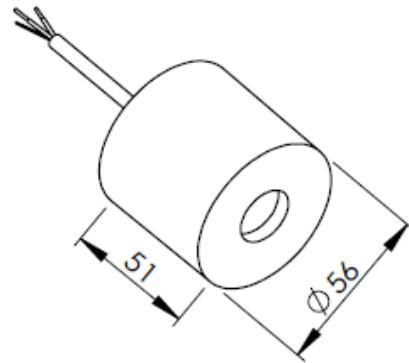

## Y100T1 100/250 kHz Air transducer

### Major Applications

Level detection  
Proximity measurement

Specifications		Dimensions		Unit: mm
	100 kHz	250 kHz		
Operation Frequency	100	250	kHz	
Capacitance (@ 1 kHz, 1Vrms)	720 ± 20%		pF	
Directivity (Full Angle @-3 dB)	10 ± 2	5 ± 2	degree	
Maximum Sensing Range	4	0.8	meter	
Blind Zone	< 20	< 7	cm	
Housing Material	PVDF			

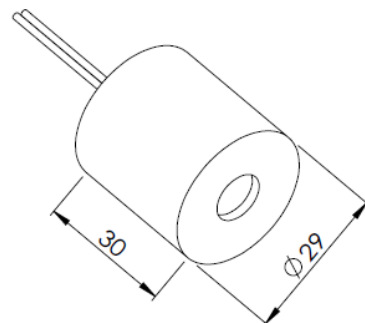

\* All specifications are subject to change without notice.

# Level Detection Through Liquid



## LPY1 1 MHz Level sensor transducer

### Major Applications

Level detection

Specifications	
Operation Frequency	1 MHz
Echo Voltage	> 50 mV
Capacitance (@ 1 kHz)	1250 ± 20% pF
Maximum Driving Voltage	50 Vpp
Operating Temperature	-20 ~ 70 °C
Storage Temperature	-30 ~ 80 °C
Dimension-Height	8 mm
Housing Material	Aluminum
Wire	UL10368 #30AWG Ø0.8mm

Dimensions	Unit: mm
------------	----------

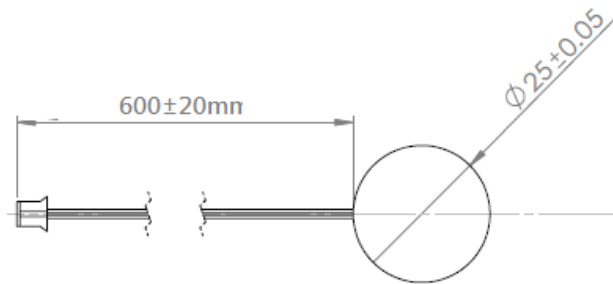

## » Sensitivity Measurement Diagram

Sensitivity measurement  
 Liquid level: 10 cm (olive oil) / container: HDPE

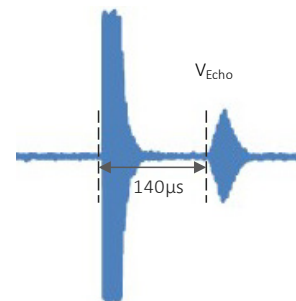
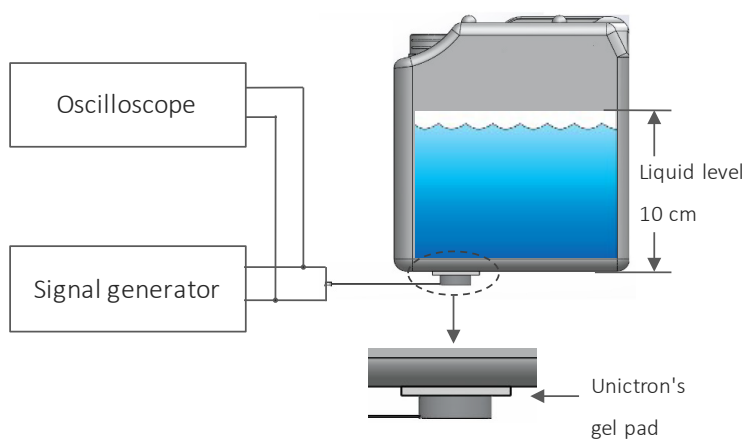

Drive Signal ( $V_{Driving}$ ): 1 MHz 3.3v 20 pulses,  
 Drive interval: 10 ms  
 Echo Signal ( $V_{Echo}$ ) : For 10 cm olive oil level,  
 echo signal appears at around 140  $\mu$ s

\* All specifications are subject to change without notice.

# Proximity Sensor



## BPY3 40 kHz Ultrasonic transducer

### Major Applications

Object and distance detection  
Waste and fill level detection

Specifications	
Operation Frequency	40 kHz
Echo Voltage*	> 200 mV
Capacitance (@ 1 kHz)	1800 ± 20% pF
Resonant Impedance	< 2000 Ohm
Operating Temperature	-40 ~ 80 °C
Storage Temperature	-10 ~ 80 °C
Dimension-Height	6.8 mm
Housing Material	Aluminum
Wire	UL1007 #24AWG Ø1.45mm

### Dimensions Unit: mm

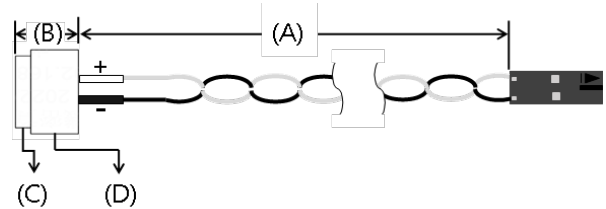

- (A) 130 ± 5
- (B) 9 ± 0.3
- (C) 12.5 ± 0.3
- (D) 14.4 ± 0.3

\* burst: 20 cycles, gain: 330 @distance: 100cm

## » Ultrasonic Time-of-Flight Measurement

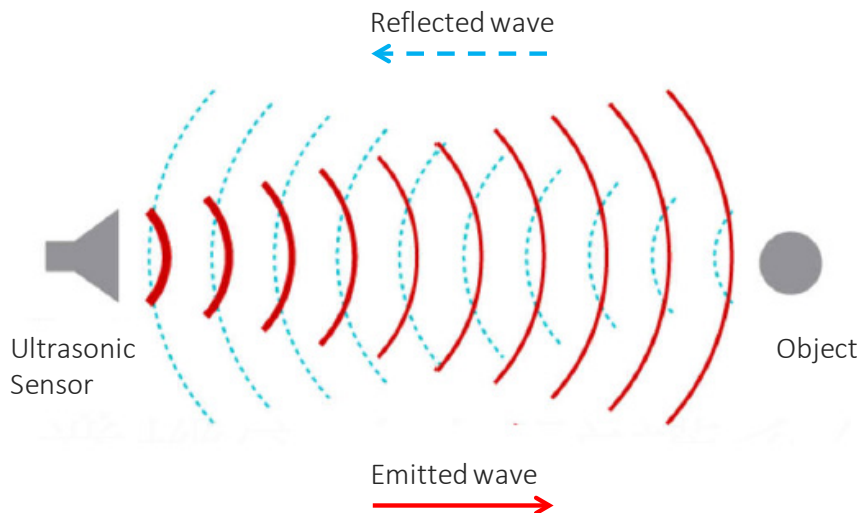

\* All specifications are subject to change without notice.

# Flow Meter for Liquid



## MPYA 1 MHz Flow meter transducer

### Major Applications

Liquid flow meter

Specifications	
Operation Frequency	1 MHz
Capacitance (@ 1 kHz)	1200 ± 20% pF
Sensitivity dB*	-28 min dB
Beam Angle (-3dB full angle)	5 degree
Operation Voltage	50 max Vpp
Operation Temperature	4 ~ 80 °C
Storage Temperature	-10 ~ 80 °C
Housing Material	PPS
Wire	UL2547 #28AWG Ø2.8mm

### Dimensions

Unit: mm

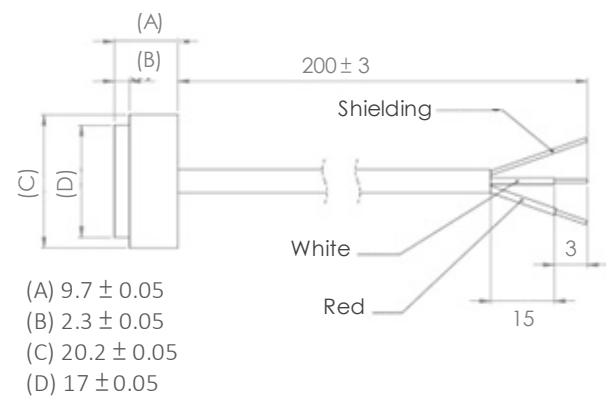

\* Applied voltage  $V_{pp} = 3.3V$ , sine wave, 20 cycles burst, Water level 10 cm; Water temperature 25°C

## » Sensitivity Measurement Diagram

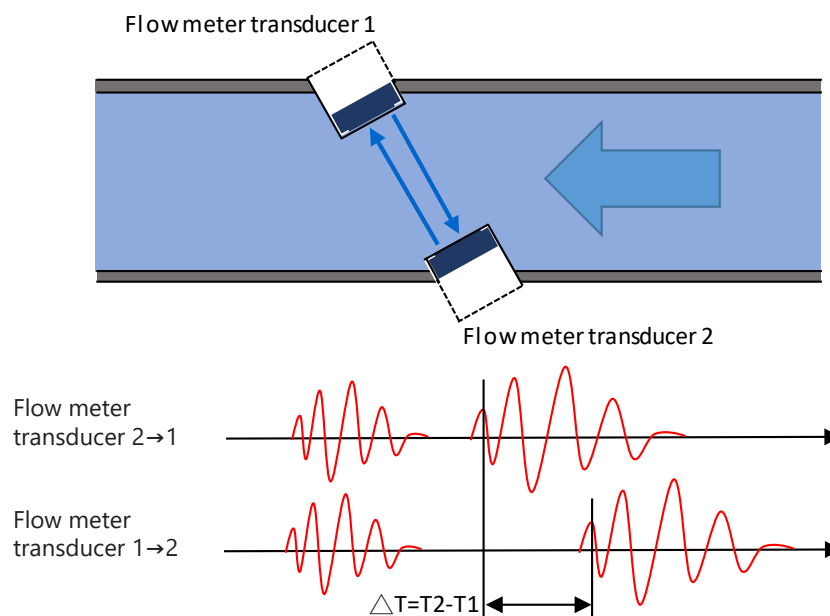







\* All specifications are subject to change without notice.









# Product Family

## Double Feed Detection / Edge Position Control

Model Name	A280A1	A300A	A330A1	A150A	A170W1	A200H1
						
Frequency (kHz)	280	300	330	150	170	200
Dimensions (mm)	OD 9.9 H 7.3	OD 9.9 H 7.3	OD 9.9 H 7.3	OD 17.15 H 12.70	L54.6W18.2 H10.0	OD 18.8 H 10.5
Directivity (full angle)	10 ± 2° (@-6 dB)	10 ± 2° (@-6 dB)	10 ± 2° (@-6 dB)	8 ± 2° (@-3 dB)	X 5 ± 2° Y 25 ± 2° (@-6 dB)	10 ± 2° (@-6 dB)
Max. Sensing Range (cm)	70	60	50	250	> 28 mm (working range)	200
Blind Zone (cm)	< 3	< 3	< 3	< 15	< 15	< 10
Housing Material	Plastic	Plastic	Plastic	Aluminum	Plastic	Aluminum
Major Applications	Web guiding Proximity Double feed	Web guiding Proximity Double feed	Web guiding Proximity Double feed	Web guiding Proximity	WireWeb guiding Proximity	Web guiding Proximity





## Non-contact Ultrasonic Level Detection

Model Name	A050A	A050B1	A054L1	A100A1	A100C1	A125A1
						
Frequency (kHz)	50	50	54	100	100	125
Dimensions (mm)	OD 47.0 H 48.0	OD 56.0 H 51.0	OD 47.0 H 48.0	OD 29.0 H 30.0	OD 29.0 H 56.1	OD 25.0 H 25.0
Directivity (full angle @-3 dB)	10 ± 2°	10 ± 2°	10 ± 2°	10 ± 2°	10 ± 2°	10 ± 2°
Max. Sensing Range (meter)	10	12	10	4	4	3
Blind Zone (cm)	< 30	< 30	< 20	< 20	< 20	< 15
Housing Material	PVDF	PVDF	PVDF	PVDF	PVDF	PVDF
Major Applications	Level detection	Level detection	Level detection	Level detection	Level detection	Level detection





\* All specifications are subject to change without notice.

# Product Family

## Non-contact Ultrasonic Level Detection

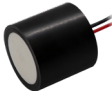
Model Name	A125E	A180M1	A200A1	A240A1	A250M1
					
Frequency (kHz)	125	180	200	240	250
Dimensions (mm)	OD 29.0 H 126.6	OD 18.2 H 5.25	OD 16.0 H 19.0	OD 13.5 H 18.5	OD 18.2 H 5.25
Directivity (full angle @-3 dB)	10 ± 2°	10 ± 2°	8 ± 2°	8 ± 2°	10 ± 2°
Max. Sensing Range (meter)	3	2	2	1.2	1
Blind Zone (cm)	< 15	< 10	< 5	< 4	< 5
Housing Material	PVDF	Elastomer	PVDF	PVDF	Elastomer
Major Applications	Level detection	Level detection	Level detection	Level detection	Level detection

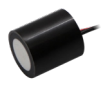



## Non-contact Ultrasonic Level Detection

Model Name	A100F1	A125F1	A200F1	A240F1
				
Frequency (kHz)	100	125	200	240
Dimensions (mm)	OD 29.0 H 28.5	OD 25.0 H 23.5	OD 16.0 H 18.0	OD 13.5 H 17.5
Directivity (full angle @-3 dB)	10 ± 2°	10 ± 2°	8 ± 2°	8 ± 2°
Max. Sensing Range (meter)	4	3	2	1.2
Blind Zone (cm)	< 20	< 15	< 5	< 4
Housing Material	PVDF	PVDF	PVDF	PVDF
Major Applications	Level detection	Level detection	Level detection	Level detection



\* All specifications are subject to change without notice.

# Product Family

## Ultrasonic Gas Flow Meter / Anemometer

Model Name	A200D1	A200M5	A240B1	A240M3	A500B1
					
Frequency (kHz)	200	200	240	240	500
Dimensions (mm)	OD 16.0 H 19.0	OD 18.2 H 8.5	OD 13.5 H 18.5	OD 18.2 H 7.0	OD 18.2 H 6.35
Directivity (full angle @-3 dB)	8 ± 2°	9 ± 2°	8 ± 2°	10 ± 2°	7 ± 2°
Operating Temperature (°C)	-25 ~ +55	-25 ~ +55	-30 ~ +60	-25 ~ +55	-25 ~ +55
Housing Material	PVDF	Elastomer	PVDF	Elastomer	Elastomer
ZFD (Zero Flow Drift)	< 1.0 ns	< 1.0 ns	< 1.0 ns	< 1.0 ns	< 1.0 ns
Major Applications	Gas flow meter	Gas flow meter	Anemometer	Gas flow meter	Gas flow meter

## Dual-frequency Non-contact Ultrasonic Level Detection

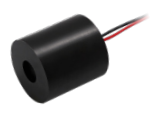
Model Name	Y050A1	Y050T1	Y100T1
			
Frequency (kHz)	50/200	50/200	100/250
Dimensions (mm)	OD 56.0 H 51.0	OD 56.0 H 51.0	OD 29.0 H 30.0
Directivity (full angle @-3 dB)	10° (@50 kHz) 6° (@200 kHz)	10° (@50 kHz) 6° (@200 kHz)	10° (@100 kHz) 5° (@250 kHz)
Max. Sensing Range (meter)	12	12	4
Blind Zone (cm)	10	10	7
Housing Material	PVDF	PVDF	PVDF
Major Applications	Level detection	Level detection	Level detection

\* All specifications are subject to change without notice.

# Product Family

## Level Detection through Liquid

Model Name	LPY1
	
Frequency (MHz)	1
Capacitance (@ 1 kHz) (pF)	1250
Echo Voltage (mV)	> 50
Maximum Driving Voltage (Vpp)	50
Dimensions (mm)	OD 25.0 H 8.0
Operating Temperature (°C)	-20 ~ 70
Storage Temperature (°C)	-30 ~ 80
Housing Material	Aluminum

## Proximity Level Detection through Air

Model Name	BPY3
	
Frequency (kHz)	40
Capacitance (@ 1 kHz) (pF)	1800
Echo Voltage (mV)	> 200
Resonant Impedance (ohm)	< 2000
Dimensions (mm)	OD 14.4 H 6.8
Operating Temperature (°C)	-40 ~ 80
Storage Temperature (°C)	-10 ~ 80
Housing Material	Aluminum

## Flow Meter for Liquids

Model Name	MPY1
	
Frequency (MHz)	1
Capacitance (@ 1 kHz) (pF)	1200
Sensitivity dB	-28 min
Beam Angle (-3 dB full angle)	5°
Operation Voltage (Vpp)	50 max
Operating Temperature (°C)	4 ~ 80
Storage Temperature (°C)	-10 ~ 80
Housing Material	PPS

\* All specifications are subject to change without notice.

## Embrace the Future: Shaping Tomorrow's Piezoceramics



By choosing Unictron, you're embracing a legacy of excellence that's continuously shaping the landscape of piezoceramics.



Here, we offer a glimpse into the vast possibilities Unictron – a world where innovation, quality, and customer-centricity converge.



Unfold the boundless opportunities that lie ahead as we embark on a journey that reshapes industries and empowers innovations.



The future of piezoceramics is here - a realm we're pioneering.

[www.unictron.com](http://www.unictron.com)



No. 83, Kewang Rd., Longtan Dist.,  
Taoyuan City 325, Taiwan  
Phone: +886-3-4072728  
E-mail: [p-sales@unictron.com](mailto:p-sales@unictron.com)