

# 500 kHz Air transducer



Model: A500A

P/N: H2KA500KA1CD00



A500A ultrasonic transducer is designed to deliver outstanding performance at around 500 kHz frequency using our in-house piezoceramic and acoustic matching layer along with state-of-art technologies. The transducer works as a signal transmitting and receiving unit. This ultrasonic transducer is suitable for gas flow detection and proximity measurement with precise control as well as extraordinary reliability.

## Features

- High performance
- High reliability
- Solvent resistance
- Patented technologies

## Major Applications

- Gas flow meter
- Proximity measurement

## Directivity Diagram

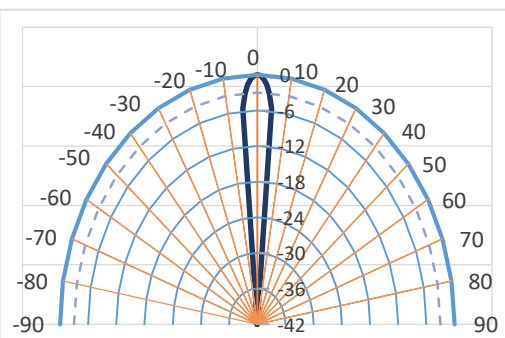

## Specifications

Operation Frequency	500 kHz
Capacitance (@ 1 kHz, 1Vrms)	320 pF
Directivity (Full Angle @-3 dB)	7 Degree
Maximum Driving Voltage	20 V <sub>p-p</sub>
Maximum Sensing Range	20 cm
Blind Zone	< 2 cm
Dimension-OD	18.2 mm
Dimension-Height	6.58 (Ref.) mm

## Dimensions

Housing material: Elastomer  
Unit: mm

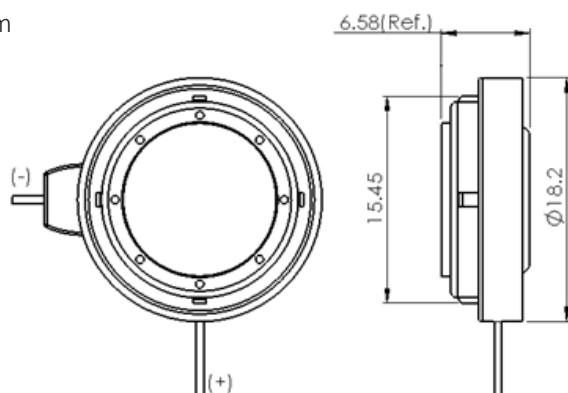

As Unictron continues to improve its products, all specifications are subject to change without notice. All specifications are typically measured at 25 ± 3 ° C, 45 to 60% RH.