

Description

The UE0306035ALCBD is a bi-directional TVS diode, utilizing leading monolithic silicon technology to provide fast response time and low ESD clamping voltage, making this device an ideal solution for protecting voltage sensitive high-speed data lines. The UE0306035ALCBD has an ultra-low capacitance with a typical value at 0.3pF, and complies with the IEC 61000-4-2 (ESD) standard with $\pm 25\text{kV}$ air and $\pm 20\text{kV}$ contact discharge. It is assembled into an ultra-small 0.6x0.3x0.3mm lead-free DFN package. The small size, ultra-low capacitance and high ESD surge protection make UE0306035ALCBD an ideal choice to protect cell phone, digital video interfaces and other high speed ports.

Mechanical Characteristics

- ◆ Package: DFN0603-2 (0.6 x0.3 x0.3mm)
- ◆ Case Material: "Green" Molding Compound.
- ◆ Moisture Sensitivity: Level 3 per J-STD-020
- ◆ Terminal Connections: See Diagram Below
- ◆ Marking Information: See Below

Dimensions and Pin Configuration

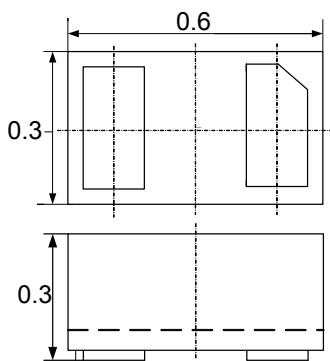

Package Dimensions

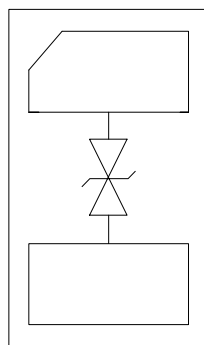

Circuit and Pin Schematic

Features

- ◆ Ultra small package: 0.6 x0.3 x0.3mm
- ◆ Ultra low capacitance: 0.3pF typical
- ◆ Ultra low leakage: nA level
- ◆ Operating voltage: 3.3V
- ◆ Low clamping voltage
- ◆ Complies with following standards:
 - IEC 61000-4-2 (ESD) immunity test
 - Air discharge: $\pm 25\text{kV}$
 - Contact discharge: $\pm 20\text{kV}$
 - IEC61000-4-5 (Lightning) 5A (8/20 μs)
- ◆ RoHS Compliant

Applications

- ◆ Cellular Handsets and Accessories
- ◆ Display Ports
- ◆ MDDI Ports
- ◆ USB Ports
- ◆ Digital Visual Interface(DVI)
- ◆ PCI Express and Serial SATA Ports

Marking Information

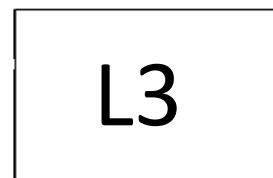

L3 = Device Marking Code

Ordering Information

Part Number	Marking	Packaging	Reel Size
UE0306035ALCBD	L3	10000/Tape & Reel	7 inch

Absolute Maximum Ratings ($T_A=25^{\circ}\text{C}$ unless otherwise specified)

Parameter	Symbol	Value	Unit
Peak Pulse Power (8/20 μs)	Ppk	100	W
Peak Pulse Current (8/20 μs)	I _{PP}	5	A
ESD per IEC 61000-4-2 (Air)	V _{ESD}	± 25	kV
ESD per IEC 61000-4-2 (Contact)		± 20	
Operating Temperature Range	T _J	-55 to +125	$^{\circ}\text{C}$
Storage Temperature Range	T _{stg}	-55 to +125	$^{\circ}\text{C}$

Electrical Characteristics ($T_A=25^{\circ}\text{C}$ unless otherwise specified)

Parameter	Symbol	Min	Typ	Max	Unit	Test Condition
Reverse Working Voltage	V _{RWM}			3.3	V	
Breakdown Voltage	V _{BR}	5			V	I _T = 1mA
Reverse Leakage Current	I _R			0.2	μA	V _{RWM} = 3.3V
Clamping Voltage	V _C			10	V	I _{PP} = 1A (8 x 20 μs pulse)
Clamping Voltage	V _C			20	V	I _{PP} = 5A (8 x 20 μs pulse)
Junction Capacitance	C _J		0.3		pF	V _R = 0V, f = 1MHz

Typical Performance Characteristics (TA=25°C unless otherwise Specified)

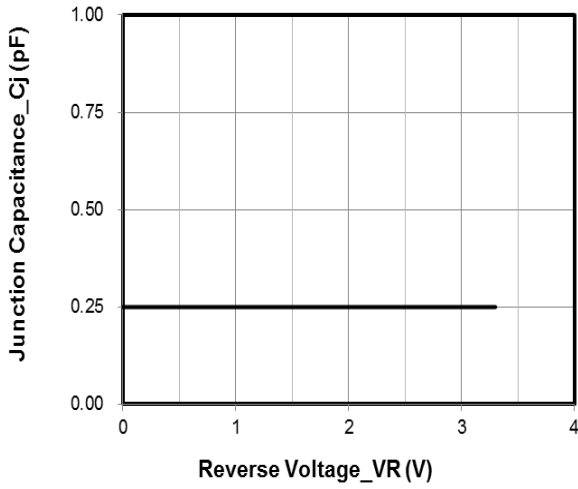

Junction Capacitance vs. Reverse Voltage

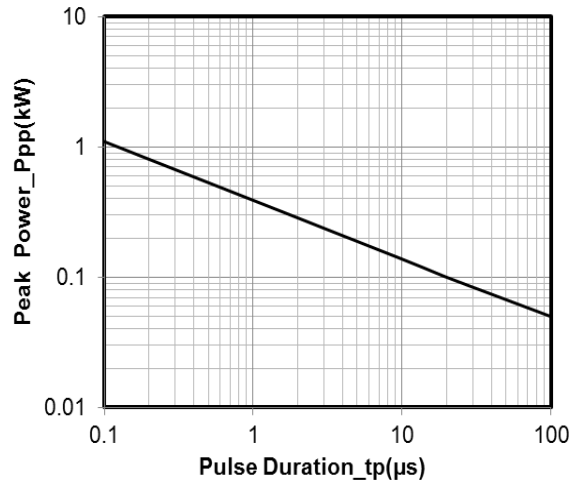

Peak Pulse Power vs. Pulse Time

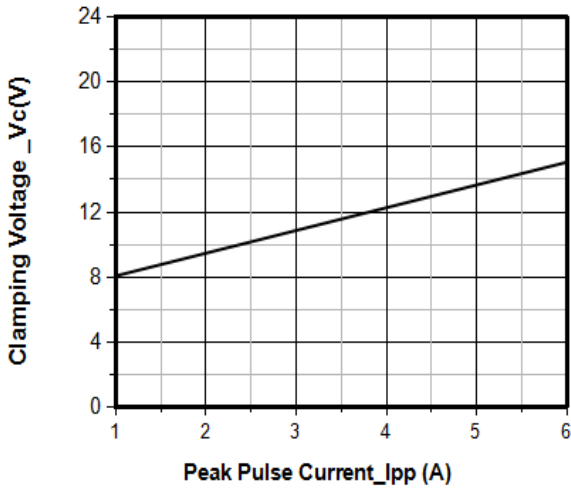

Clamping Voltage vs. Peak Pulse Current

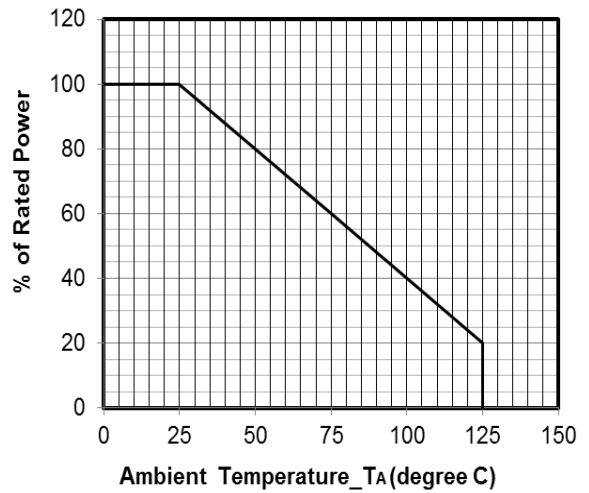

Power Derating Curve

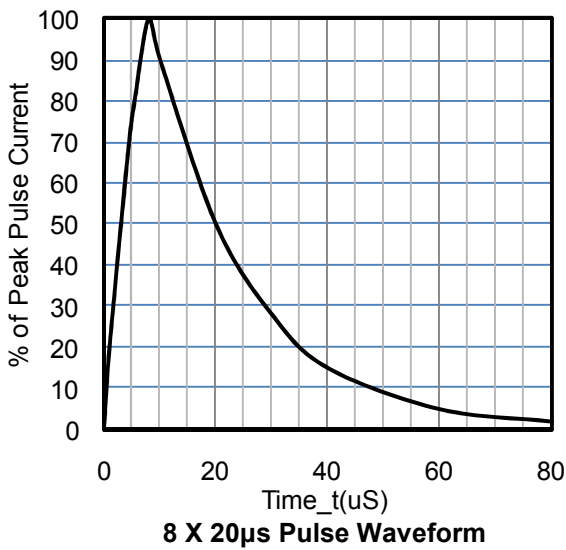

8 X 20μs Pulse Waveform

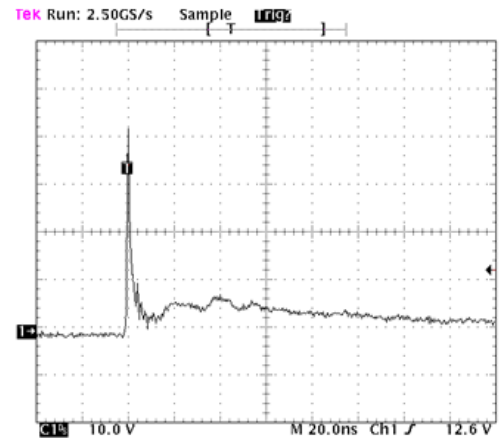

Note: Data is taken with a 10x attenuator

ESD Clamping Voltage

8 kV Contact per IEC61000-4-2

DFN0603-2 Package Outline Drawing

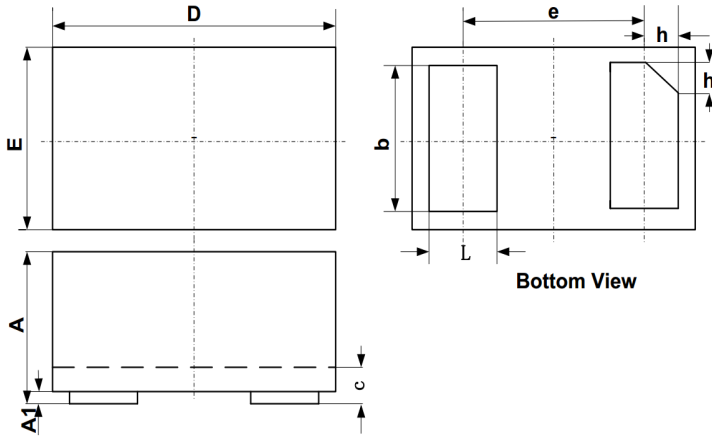

SYM	DIMENSIONS		
	MILLIMETERS		
	MIN	NOM	MAX
A	0.230		0.330
A1	0.000	0.020	0.050
b	0.215	0.245	0.275
c	0.120	0.150	0.180
D	0.550	0.600	0.650
e	0.355 BSC		
E	0.250	0.300	0.350
L	0.160	0.190	0.220
h	0.079 BSC		

Suggested Land Pattern

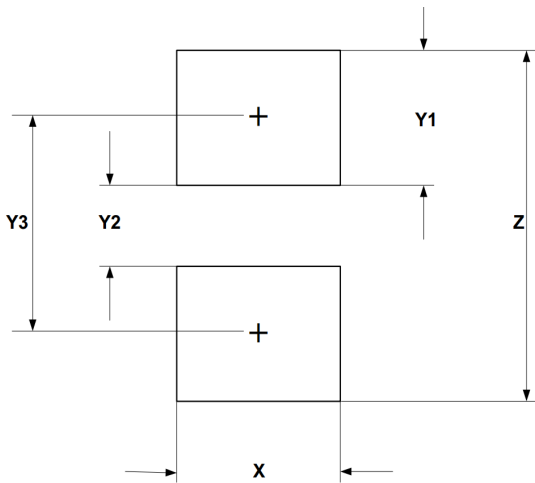

SYM	DIMENSIONS	
	MILLIMETERS	INCHES
X	0.30	0.012
Y1	0.25	0.010
Y2	0.15	0.006
Y3	0.40	0.016
Z	0.65	0.026