

Features

- 350 watts peak pulse power ($t_p = 8/20\mu s$)
- Unidirectional & Bidirectional Configurations
- Working Voltages: 3.3V, 5V, 12V, 15V, 24V and 36V
- Low clamping voltages
- Low Leakage Current
- Response Time is Typically < 1 ns
- AEC-Q101 Qualified

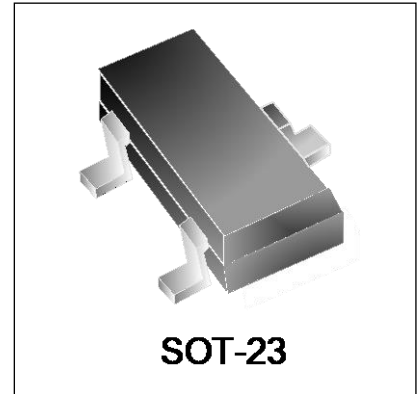

IEC COMPATIBILITY (EN61000-4)

- IEC 61000-4-2 (ESD) $\pm 30kV$ (air), $\pm 30kV$ (contact)
- IEC 61000-4-4 (EFT) 40A (5/50ns)

Mechanical Characteristics

- JEDEC SOT-23 package
- Molding compound flammability rating: UL 94V-0
- Marking: Marking Code
- Packaging: Tape and Reel per EIA 481
- RoHS Compliant

Applications

- RS-232, RS-422 & RS-485
- Cellular Handsets and Accessories
- Control & Monitoring Systems
- Portable Electronics
- Set-Top Box
- Servers, Notebook, and Desktop PC
- Wireless Bus Protection

Schematic & PIN Configuration

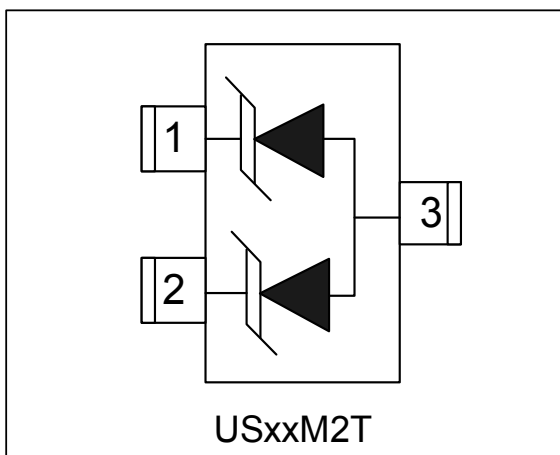

Absolute Maximum Rating			
Rating	Symbol	Value	Units
Peak Pulse Power ($t_p=8/20\mu s$)	P_{PP}	350	Watts
Lead Soldering Temperature	T_L	260(10sec)	°C
Operating Temperature	T_J	-55 to + 125	°C
Storage Temperature	T_{STG}	-55 to +125	°C

Electrical Parameters (T=25°C)

Symbol	Parameter
I_{PP}	Reverse Peak Pulse Current
V_C	Clamping Voltage @ I_{PP}
V_{RWM}	Reverse Stand-Off Voltage
I_R	Reverse Leakage Current @ V_{RWM}
V_{BR}	Breakdown Voltage @ I_T
I_T	Test Current
I_F	Forward Current
V_F	Forward Voltage @ I_F

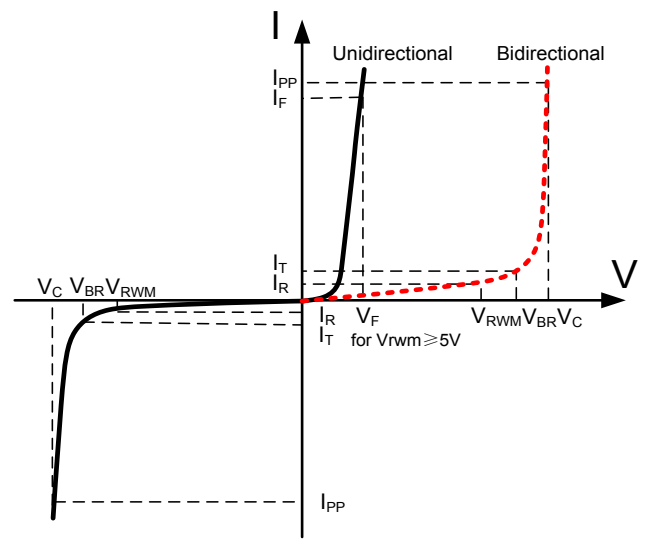

Electrical Characteristics

Part Number	Reverse Stand off Voltage V_{RWM} (Volts)	Minimum Breakdown Voltage $V_{BR}@1mA$ (Volts)	Maximum Peak Pulse Current I_{PP} (Amps)	Maximum Clamping Voltage $V_C@I_{PP}$ (Volts)	Maximum Reverse Leakage $I_R@V_{RWM}$ (μA)	Typical Capacitance DC=0V $C_J@1MHz$ (pF)	Maximum Capacitance DC=0V $C_J@1MHz$ (pF)	Marking Code
US03M2T	3.3	4.0	25	15	1	200	240	3M2
US05M2T	5	6.0	20	25	1	150	180	5M2
US12M2T	12	13.3	12	30	1	50	60	AM2
US15M2T	15	16.7	10	35	1	45	55	BM2
US24M2T	24	26.7	6	55	1	30	40	CM2
US36M2T	36	40	6	95	1	25	30	DM2

Typical Characteristics

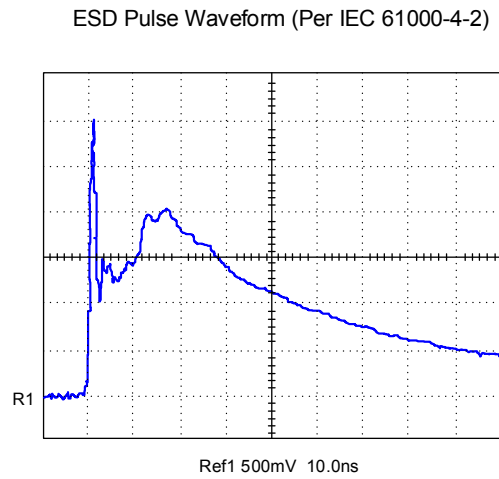
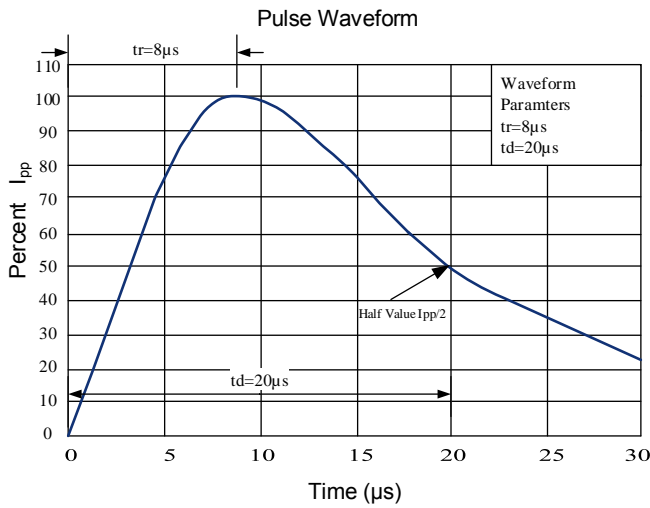
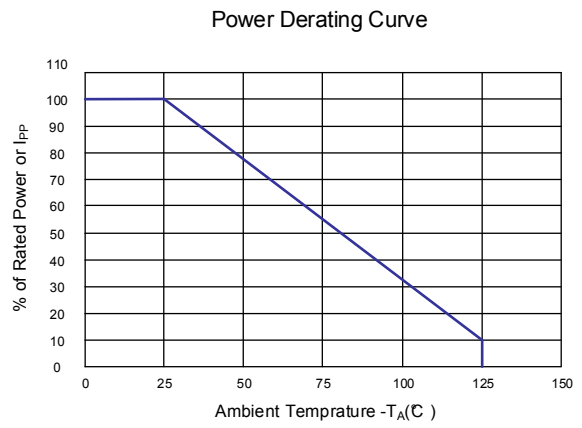
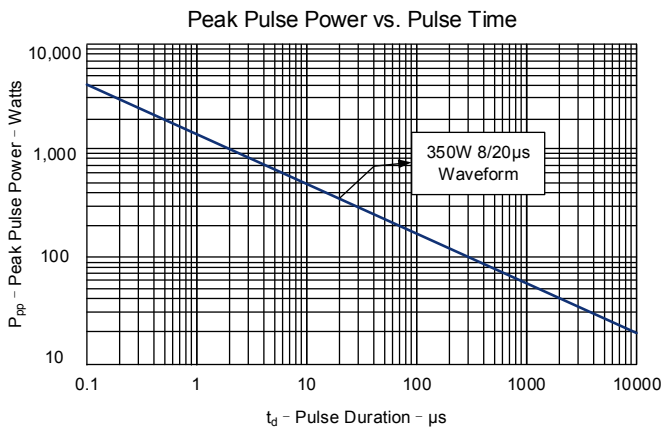

Outline Drawing – SOT-23

PACKAGE OUTLINE

SOT-23

DIMENSIONS				
SYMBOL	MILLIMETER		INCHES	
	MIN	MAX	MIN	MAX
A	0.90	1.15	0.035	0.045
A1	0.00	0.10	0.000	0.004
A2	0.60	0.70	0.0236	0.0275
b	0.30	0.50	0.012	0.020
c	0.08	0.15	0.003	0.006
D	2.80	3.00	0.110	0.118
E	2.25	2.55	0.089	0.100
E1	1.20	1.40	0.047	0.055
e	0.95 BSC		0.0374 BSC	
e1	1.80	2.00	0.071	0.079
L	0.30	0.50	0.012	0.020
θ	0	8°	0	8°

DIMENSIONS		
DIM	INCHES	MILLIMETERS
M	0.0795	2.02
C	0.0315	0.80
Z	0.111	2.82
e	0.037 BSC	0.95 BSC
e1	0.075 BSC	1.9 BSC
b	0.0315	0.80

Notes

1. Dimensioning and tolerances per ANSI Y14.5M, 1985.
2. Controlling Dimension: Inches
3. Pin 3 is the cathode (Unidirectional Only).
4. Dimensions are exclusive of mold flash and metal burrs.

Marking Codes

Part Number	USxxM2T
Marking Code	

Package Information

Qty: 3k/Reel