

Description

The UL0522P6-SB is a low capacitance TVS (Transient Voltage Suppressor) designed to protect high speed data interfaces. It has been specifically designed to protect sensitive electronic components which are connected to data and transmission lines from over-stress caused by ESD (Electrostatic Discharge). The UL0522P6-SB incorporates two pairs of low capacitance steering diodes plus a TVS diode. The UL0522P6-SB may be used to provide ESD protection up to $\pm 30\text{kV}$ (contact discharge) according to IEC61000-4-2, and withstand peak pulse current up to 11A (8/20 μs) according to IEC61000-4-5.

Mechanical Characteristics

- ◆ Package: DFN1610-6
- ◆ Lead Finish: Matte Tin
- ◆ Case Material: "Green" Molding Compound.
- ◆ Moisture Sensitivity: Level 3 per J-STD-020
- ◆ Terminal Connections: See Diagram Below
- ◆ Marking Information: See Below

Features

- ◆ Ultra low capacitance: 0.15pF typical
- ◆ Ultra low leakage: nA level
- ◆ Operating voltage: 5V
- ◆ Low clamping voltage
- ◆ Up to 2-line protects
- ◆ Complies with following standards:
 - IEC 61000-4-2 (ESD) immunity test
 - Air discharge: $\pm 30\text{kV}$
 - Contact discharge: $\pm 30\text{kV}$
 - IEC61000-4-5 (Lightning) 11A (8/20 μs)
- ◆ RoHS Compliant

Applications

- ◆ Cellular Handsets and Accessories
- ◆ Display Ports
- ◆ MDDI Ports
- ◆ USB 2.0 and 3.0 Ports
- ◆ HDMI 1.3 and 1.4
- ◆ Digital Visual Interface (DVI)
- ◆ PCI Express and Serial SATA Ports
- ◆ Notebook Computer

Dimensions and Pin Configuration

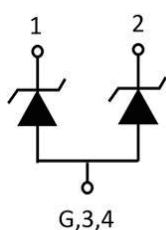

Circuit Schematic

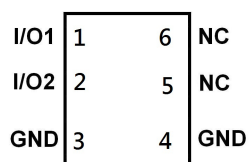

PIN Schematic

Marking Information



0522P = Device Marking Code

Dot denotes Pin1

Ordering Information

Part Number	Marking	Packaging	Reel Size
UL0522P6-SB	0522P	3000/Tape & Reel	7 inch

Absolute Maximum Ratings ($T_A=25^\circ\text{C}$ unless otherwise specified)

Parameter	Symbol	Value	Unit
Peak Pulse Power (8/20 μs)	Ppk	55	W
Peak Pulse Current (8/20 μs)	I _{PP}	11	A
ESD per IEC 61000-4-2 (Air)	V _{ESD}	± 30	kV
ESD per IEC 61000-4-2 (Contact)		± 30	
Operating Temperature Range	T _J	-55 to +125	$^\circ\text{C}$
Storage Temperature Range	T _{stg}	-55 to +150	$^\circ\text{C}$

Electrical Characteristics ($T_A=25^\circ\text{C}$ unless otherwise specified)

Parameter	Symbol	Condition	Min.	Typ.	Max.	Unit
Reverse maximum working voltage	V _{RWM}				5.0	V
Reverse leakage current	I _R	V _{RWM} = 5V			100	nA
Reverse breakdown voltage	V _{BR}	I _T = 1mA	6.5		9.5	V
Forward voltage	V _F	I _T = 10mA	0.6	0.9	1.2	V
Clamping voltage ¹⁾	V _{CL}	I _{PP} = 16A, t _p = 100ns		5.8		V
Dynamic resistance ¹⁾	R _{DYN}			0.16		Ω
Clamping voltage ²⁾	V _{CL}	V _{ESD} = 8kV		5.5		V
Clamping voltage ³⁾	V _{CL}	I _{PP} = 1A, t _p = 8/20 μs			4.0	V
		I _{PP} = 11A, t _p = 8/20 μs			7.0	V
Junction capacitance	C _J	V _{GND} = 0V, V _{IN} = 1.5V, f = 1MHz, T = 25 $^\circ\text{C}$, Any I/O to GND		1.50	1.75	pF
		V _{GND} = 0V, V _{IN} = 1.5V, f = 1MHz, T = 25 $^\circ\text{C}$, Between I/O1 and I/O2		0.15	0.20	pF

Notes:

- 1) TLP parameter: $Z_0 = 50 \Omega$, $t_p = 100\text{ns}$, $t_f = 2\text{ns}$, averaging window from 60ns to 80ns. R_{DYN} is calculated from 4A to 16A.
- 2) Contact discharge mode, according to IEC61000-4-2.
- 3) Non-repetitive current pulse, according to IEC61000-4-5.

Typical Performance Characteristics (TA=25°C unless otherwise Specified)

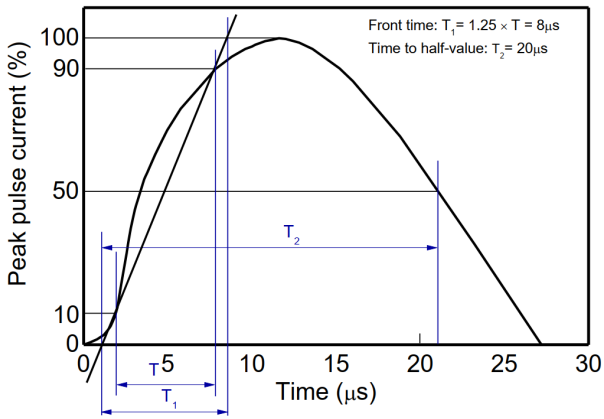

8/20μs waveform per IEC61000-4-5

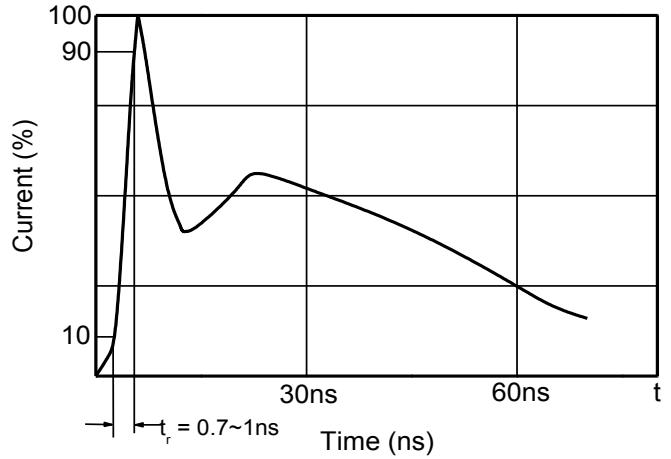

Contact discharge current waveform per IEC61000-4-2

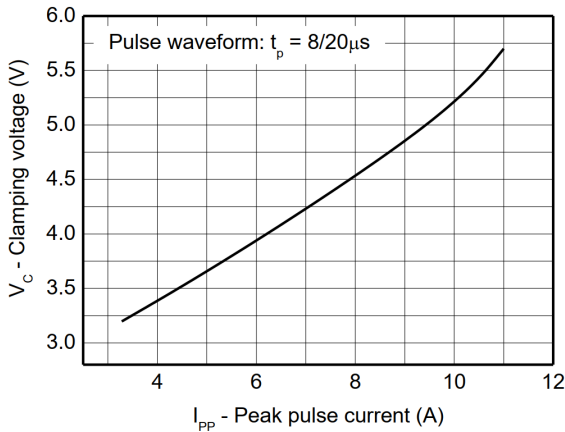

Clamping voltage vs. Peak pulse current

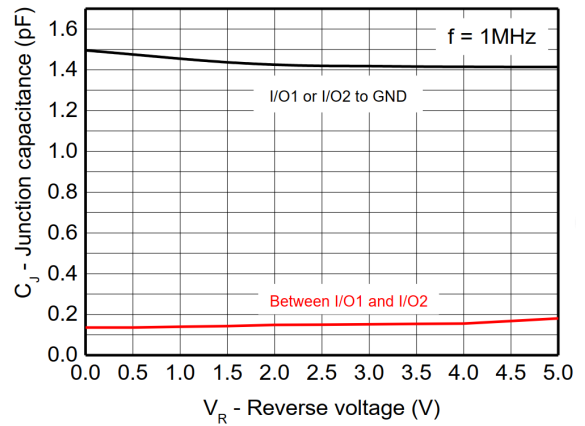

Capacitance vs. Reverse voltage

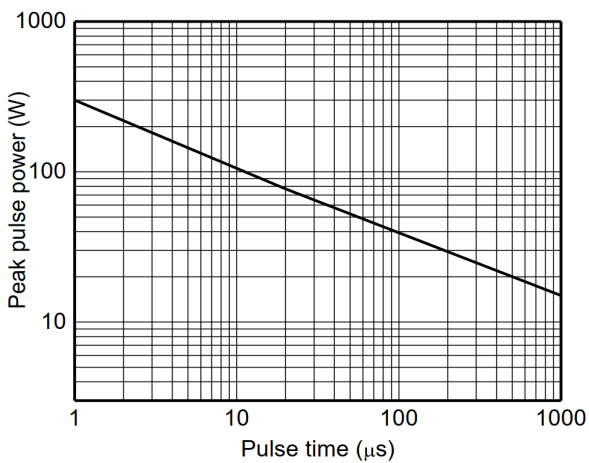

Non-repetitive peak pulse power vs. Pulse time

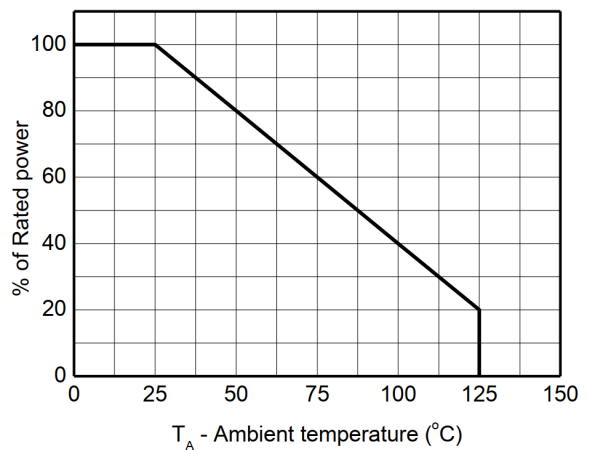

Power derating vs. Ambient temperature

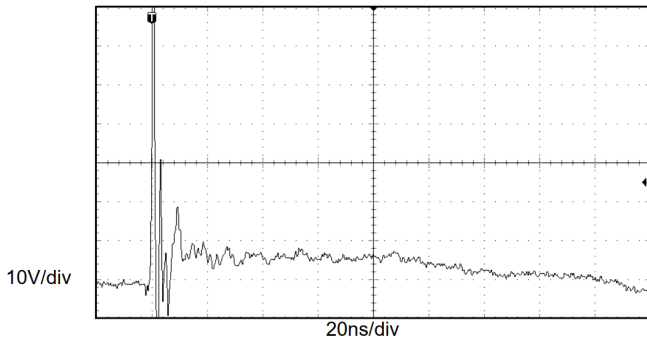

ESD clamping
 (+8kV contact discharge per IEC61000-4-2)

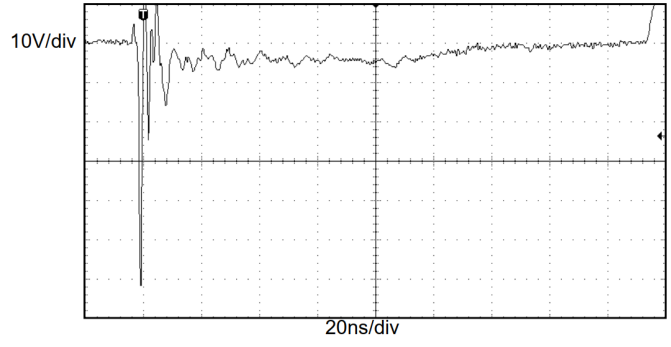

ESD clamping
 (-8kV contact discharge per IEC61000-4-2)

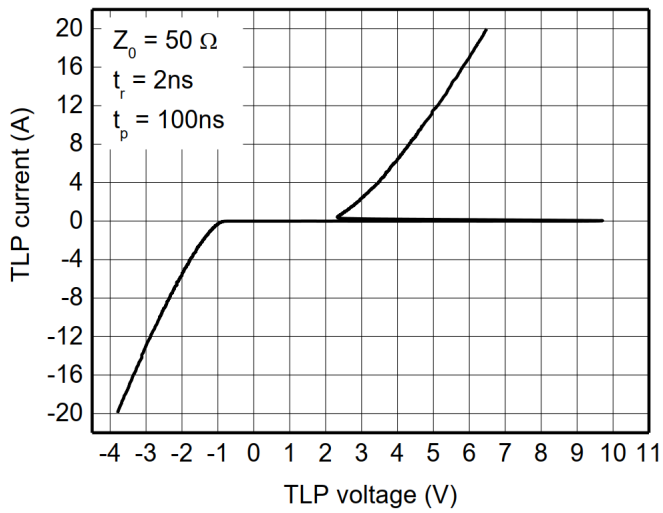

TLP Measurement

DFN1610-6 Package Outline Drawing

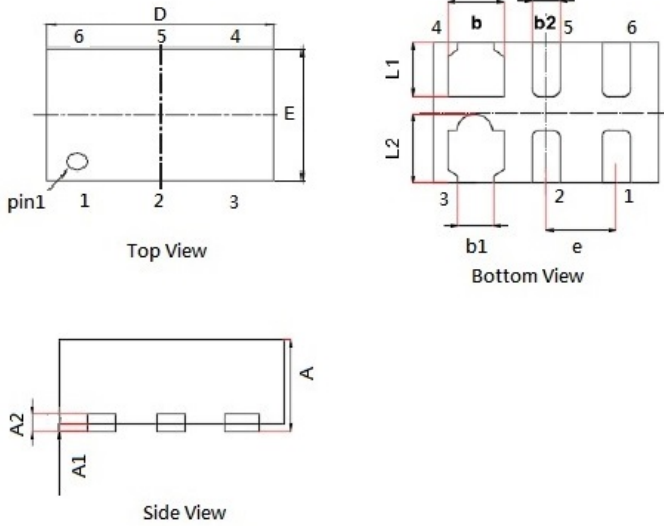

Symbol	Dimensions In Millimeters		
	MIN	NOM	MAX
A	0.45	0.50	0.55
A1	-	0.02	0.05
A2	0.12	0.15	0.20
D	1.55	1.60	1.65
E	0.95	1.00	1.05
b	0.35	0.40	0.45
b1	0.20	0.25	0.30
b2	0.15	0.20	0.25
e	0.5TYP.		
L1	0.33	0.38	0.43
L2	0.44	0.49	0.54

Recommended soldering pad layout

(Unit : mm)

