

## Description

The UL0506PA is an ultra low capacitance TVS array, utilizing leading monolithic silicon technology to provide fast response time and low ESD clamping voltage, making this device an ideal solution for protecting voltage sensitive high-speed data lines. The UL0506PA has an ultra-low capacitance with a typical value at 0.3pF, and complies with the IEC 61000-4-2 (ESD) standard with  $\pm 25\text{kV}$  air and  $\pm 20\text{kV}$  contact discharge. It is assembled into a 10-pin 4.1x2.0x0.55mm lead-free DFN package. The flow through style package allows for easy PCB lay-out and matched trace lengths necessary to maintain consistent impedance between high speed differential lines. The small size, ultra-low capacitance and high ESD surge protection make UL0506PA an ideal choice to protect HDMI 1.4, USB 3.0 and other high speed ports.

## Mechanical Characteristics

- ◆ Package: DFN4120-10 (4.1x2.0x0.55mm)
- ◆ Case Material: "Green" Molding Compound.
- ◆ Moisture Sensitivity: Level 3 per J-STD-020
- ◆ Terminal Connections: See Diagram Below
- ◆ Marking Information: See Below

## Dimensions and Pin Configuration

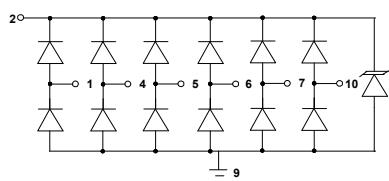

Circuit Schematic

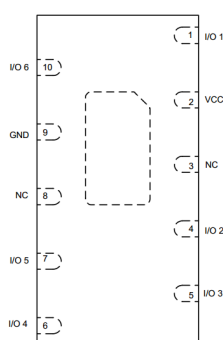

Pin Schematic

## Features

- ◆ Ultra low capacitance: 0.3pF typical
- ◆ Ultra low leakage: nA level
- ◆ Low operating voltage: 5V
- ◆ Low clamping voltage
- ◆ Protects one power line and six data lines
- ◆ Leadless flow-through package
- ◆ Complies with following standards:
  - IEC 61000-4-2 (ESD) immunity test
    - Air discharge:  $\pm 25\text{kV}$
    - Contact discharge:  $\pm 20\text{kV}$
  - IEC 61000-4-5 (Lightning) 4A (8/20 $\mu\text{s}$ )
- ◆ RoHS Compliant

## Applications

- ◆ USB3.0
- ◆ HDMI 1.4
- ◆ High-Speed Data Lines

## Marking Information

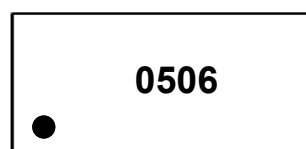

0506 = Device Marking Code  
Dot denotes pin1

## Ordering Information

Part Number	Marking	Packaging	Reel Size
UL0506PA	0506	3000/Tape & Reel	7 inch

**Absolute Maximum Ratings ( $T_A=25^{\circ}\text{C}$  unless otherwise specified)**

Parameter	Symbol	Value	Unit
Peak Pulse Power (8/20 $\mu\text{s}$ )	Ppk	60	W
Peak Pulse Current (8/20 $\mu\text{s}$ )	I <sub>PP</sub>	4	A
ESD per IEC 61000-4-2 (Air)	V <sub>ESD</sub>	$\pm 25$	kV
ESD per IEC 61000-4-2 (Contact)		$\pm 20$	
Operating Temperature Range	T <sub>J</sub>	-55 to +125	$^{\circ}\text{C}$
Storage Temperature Range	T <sub>stg</sub>	-55 to +125	$^{\circ}\text{C}$

**Electrical Characteristics ( $T_A=25^{\circ}\text{C}$  unless otherwise specified)**

Parameter	Symbol	Min	Typ	Max	Unit	Test Condition
Reverse Working Voltage	V <sub>RWM</sub>			5	V	Any I/O pin to ground
Breakdown Voltage	V <sub>BR</sub>	6			V	I <sub>T</sub> = 1mA, any I/O pin to ground
Reverse Leakage Current	I <sub>R</sub>			0.5	$\mu\text{A}$	V <sub>RWM</sub> = 5V, any I/O pin to ground
Clamping Voltage	V <sub>C</sub>			12	V	I <sub>PP</sub> = 1A (8 x 20 $\mu\text{s}$ pulse), any I/O pin to ground
Clamping Voltage	V <sub>C</sub>			15	V	I <sub>PP</sub> = 4A (8 x 20 $\mu\text{s}$ pulse), any I/O pin to ground
Junction Capacitance	C <sub>J</sub>		0.30	0.40	pF	V <sub>R</sub> = 0V, f = 1MHz, any I/O pin to ground

**Typical Performance Characteristics (TA=25°C unless otherwise Specified)**

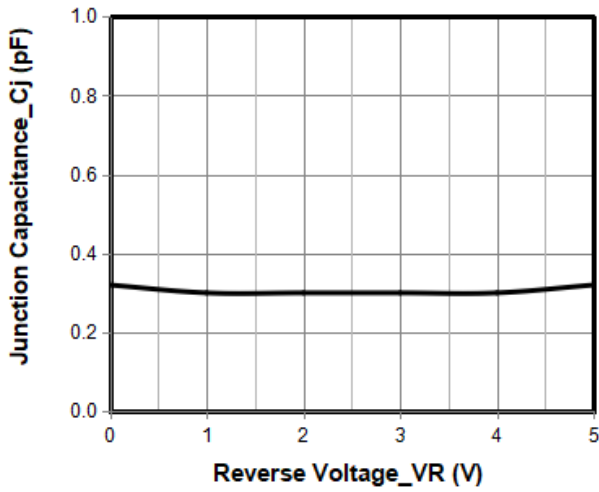

Junction Capacitance vs. Reverse Voltage

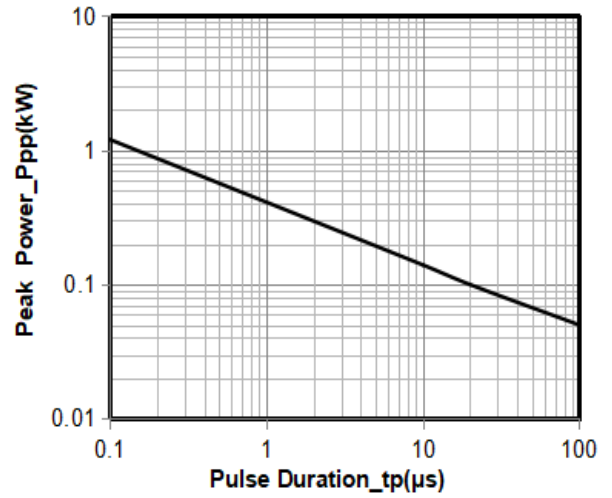

Peak Pulse Power vs. Pulse Time

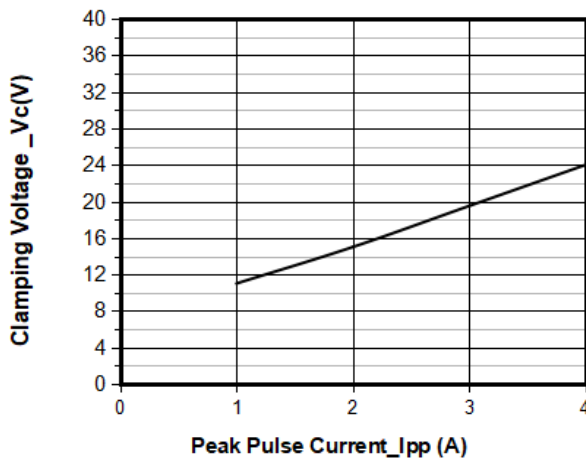

Clamping Voltage vs. Peak Pulse Current

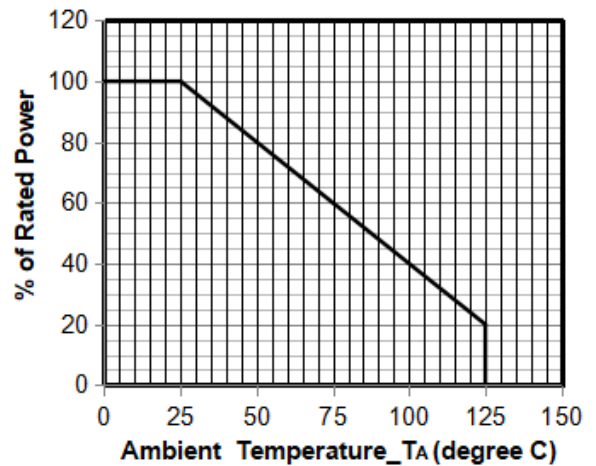

Power Derating Curve

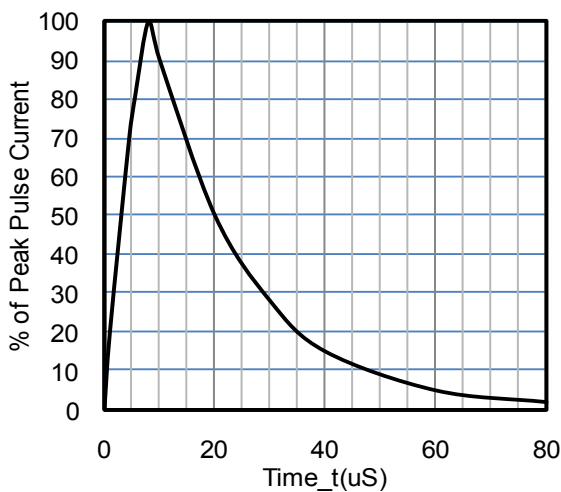

8 X 20μs Pulse Waveform

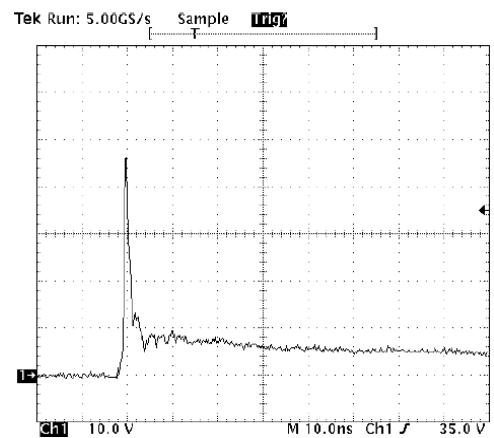

Note: Data is taken with a 10x attenuator  
**ESD Clamping Voltage**  
**8 kV Contact per IEC61000-4-2**

## Typical Application

The UL0506PA is designed for easy PCB layout by allowing the traces to run straight through the device. The protected data lines are normally connected at pins 1, 4, 5, 6, 7 & 10, pin 9 is connected to ground. The connection to ground should be made directly to a ground plane. The path length should also be kept as short as possible to minimize parasitic inductance. Pin 2 can be connected to Vcc biased or left not connected depending upon the application.

## UL0506PA on USB3.0 Application

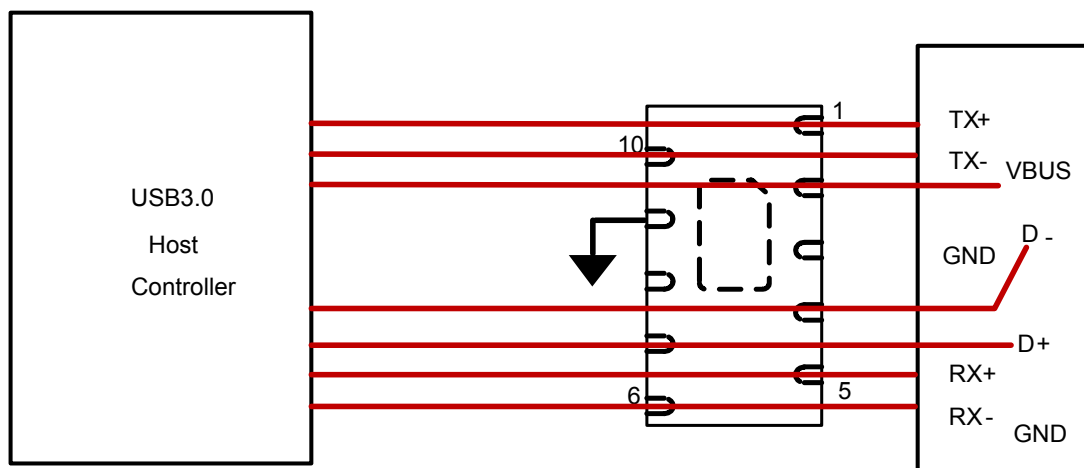

### DFN4120-10 Package Outline Drawing

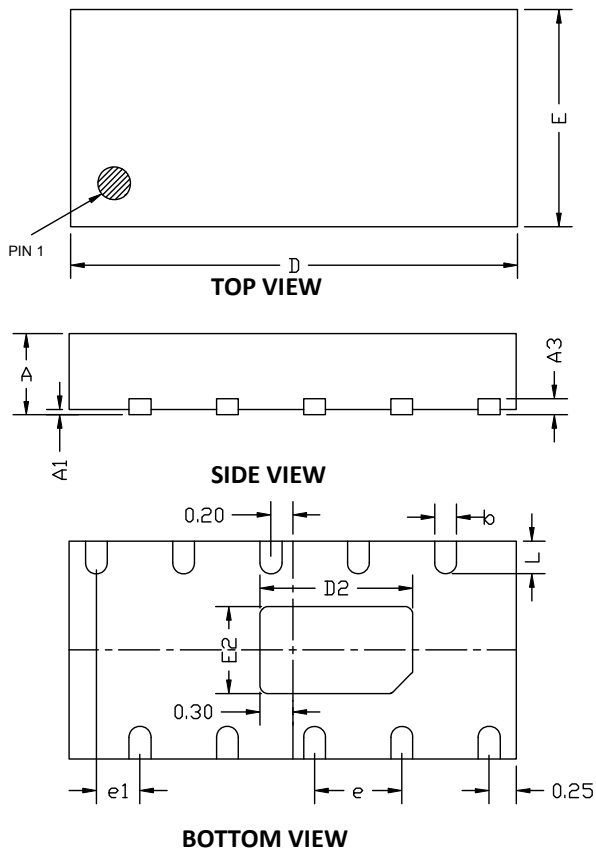

SYM	DIMENSIONS					
	MILLIMETERS			INCHES		
	MIN	NOM	MAX	MIN	NOM	MAX
A	0.50	0.55	0.60	0.020	0.022	0.024
A1	0.00		0.05	0.000		0.002
A3	0.15 REF			0.006 REF		
D	4.05	4.10	4.15	0.162	0.164	0.166
E	1.95	2.00	2.05	0.075	0.080	0.082
D2	1.25	1.40	1.50	0.050	0.056	0.060
E2	0.65	0.80	0.90	0.026	0.032	0.036
b	0.15	0.20	0.25	0.006	0.008	0.010
L	0.20	0.30	0.40	0.008	0.012	0.016
e1	0.40 BSC			0.016 BSC		
e	0.80 BSC			0.032 BSC		

### Suggested Land Pattern

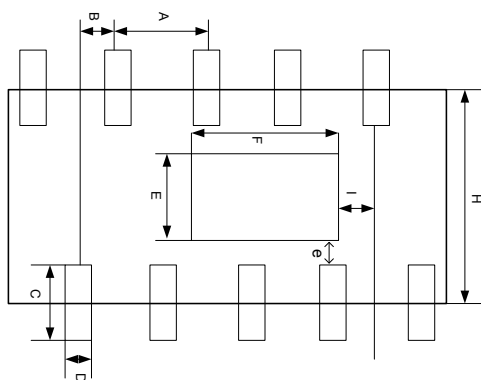

SYM	DIMENSIONS	
	MILLIMETERS	INCHES
A	0.800	0.032
B	0.400	0.016
C	0.600	0.024
D	0.200	0.008
E	0.800	0.032
F	1.400	0.056
H	2.000	0.080
I	0.300	0.012
e	0.200	0.008