

Description

UE2510AQ12 four channel array polymeric ESD suppressor provide ESD protection for high-speed differential bus interfaces. This protection is a result of its ultra-low capacitance (0.05pF) that is well suited for HDMI1.3/1.4、USB3.0 ESD protection applications, and it can be used to meet the ESD immunity requirements of IEC61000-4-2 (15KV air, 8KV contact discharge).

Features

- The best ESD protection for high speed, low voltage applications (e.g. HDMI1.3/1.4、USB3.0、eSATA)
- RoHS compliant and halogen free
- Ultra low capacitance, 0.05 pF (typ.)
- Low leakage current (<10nA)
- Fast response time (<1ns)
- Bi-directional, four (4) channel array
- Surface mount
- MSL 1

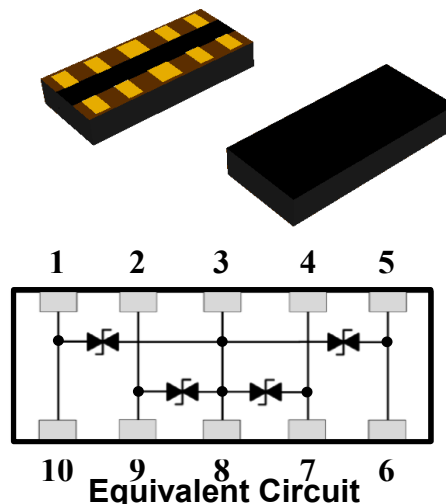

Materials Information

RoHS Compliant

Halogen Free

RoHS

HF

Applications

- HDTV/Smart TV
- Set-Top Box
- Laptop/Desktop Computer
- High Definition Multimedia Interface (HDMI)
- USB 3.0
- Lightning and Thunder Bolt Interface

Caution: This component is designed for signal line protection only, not intended to be used on power lines or for power bus applications.

General Characteristics

Parameter	Value	Unit
Contact Discharge Voltage Per IEC61000-4-2	8K	V
Air Discharge Voltage Per IEC61000-4-2	15K	V
Operating Temperature	-55 to +125	°C
Storage Temperature	-40 to +85	°C

Electrical Characteristics (T_A =25°C)

Parameter	Symbol	Test Conditions	Min.	Typ.	Max.	Units
Continuous Operating Voltage	V _{DC}	---	---	---	12	V
Trigger Voltage	V _T	IEC61000-4-2 8KV contact discharge	---	450	---	V
Clamping Voltage	V _C	IEC61000-4-2 8KV contact discharge	---	40	---	V
Leakage Current	I _L	DC 12V shall be applied on component	---	---	10	nA
Capacitance	C _P	Measured at 10MHz	---	0.05	---	pF
ESD Pulse Withstand	Pulses	IEC61000-4-2 8KV contact discharge	1000	---	---	---

Notes:

1. Trigger and clamping voltage are measured per IEC 61000-4-2, 8KV contact discharge method.
2. After reliability tests such as high Temp storage, Temp cycles, continuous ESD strike etc, the maximum leakage current is less than 1uA.

Environmental Specifications

	Solder Heat	Solderability	Preconditioning	Thermal Shock	Bias Humidity Test
Test Conditions	1. 150°C, 4H; 2. 260°C, 10s, 1 Times	245°C, 5s	1. 125°C, 24H; 2. 85°C, 85%RH, 162H; 3. 260°C Reflow, 3 Times	-55°C—125°C, 30min dwell, 1000cycles	85°C, 85%RH, V _{DC} , 1000H
Pass/Fail Criteria	90% Coverage	95% Coverage	I _L ≤10nA	I _L ≤10nA	I _L ≤10nA
	Bias Heat Test	Bias Low Temp Test	Vibration	Mechanical Shock	Solvent Resistance
Test Conditions	125°C, V _{DC} , 1000H	-55°C, V _{DC} , 1000H	10Hz-50Hz-10HZ, 2hrs each in X-Y-Z axis	1500G, 0.5ms, X-Y-Z axis 3 times	IPA, ultrasonic 300s
Pass/Fail Criteria	I _L ≤10nA	I _L ≤10nA	No Physical Damage I _L ≤10nA	No Physical Damage I _L ≤10nA	No Physical Damage I _L ≤10nA

Typical Device Capacitance VS. Frequency

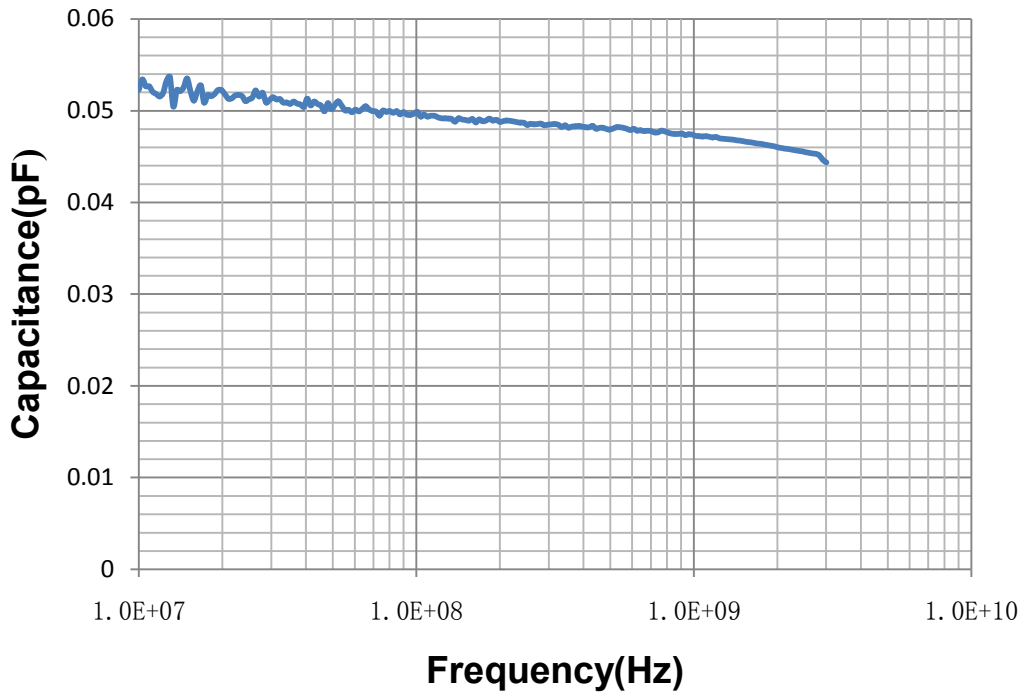

Typical ESD Response (IEC 61000-4-2, 8KV contact discharge)

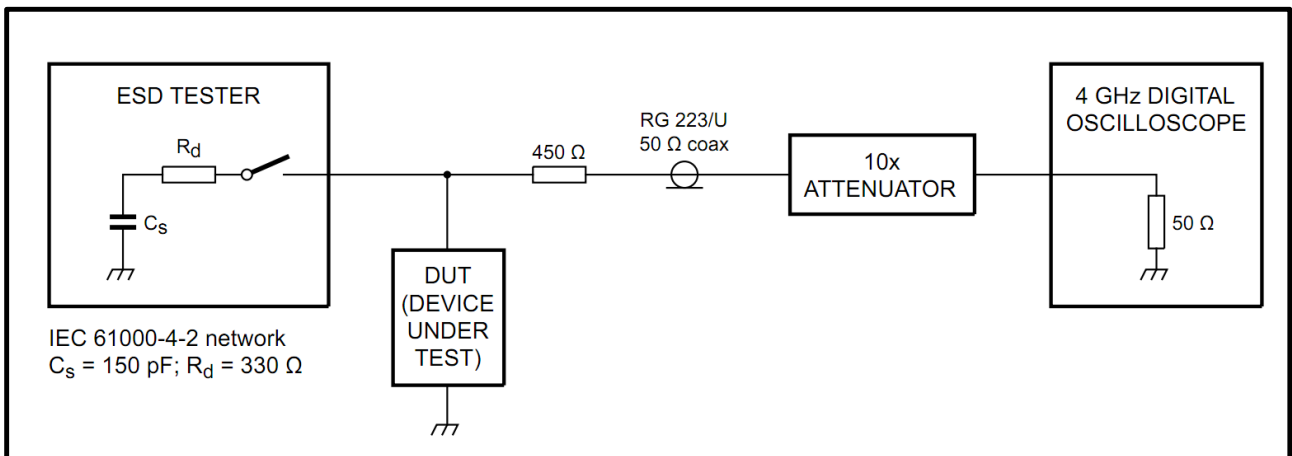

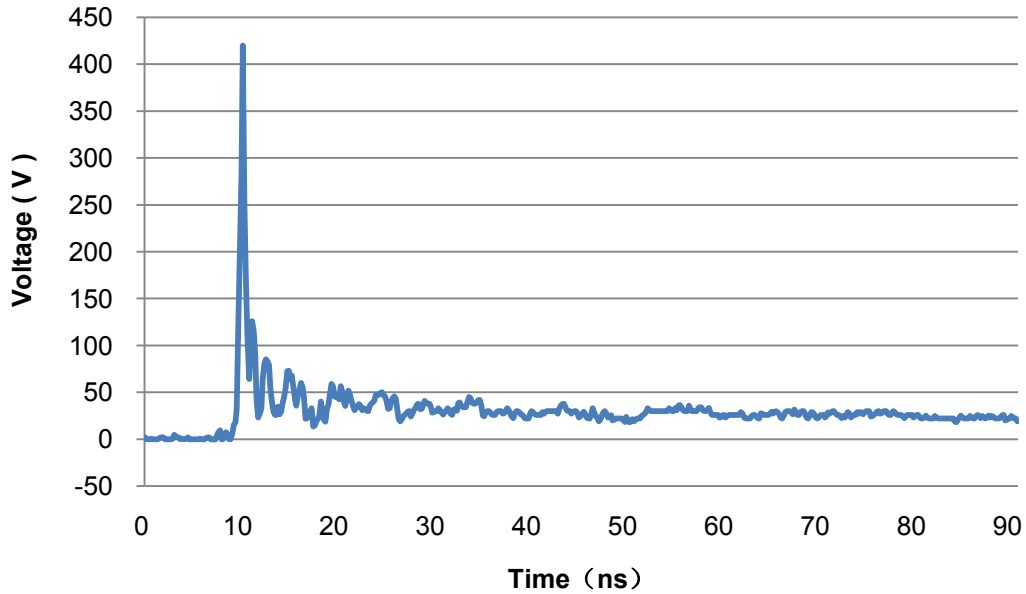

Eye Diagram Measurement

**HDMI1.4 Mask at 3.4 Gb/s
without UESD**

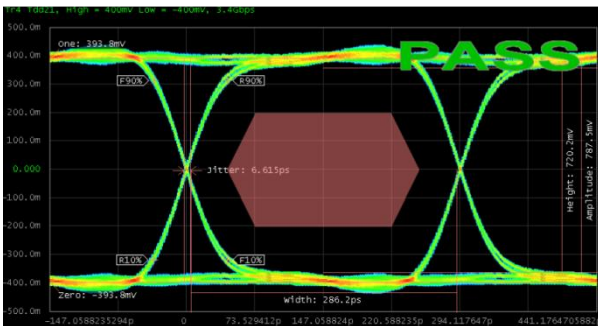

**HDMI1.4 Mask at 3.4 Gb/s
with UESD**

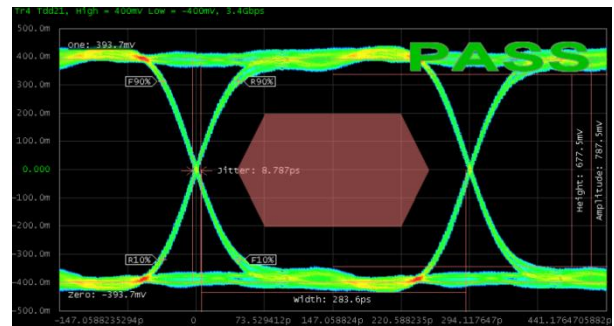

**USB3.0 Mask at 5.0 Gb/s
without UESD**

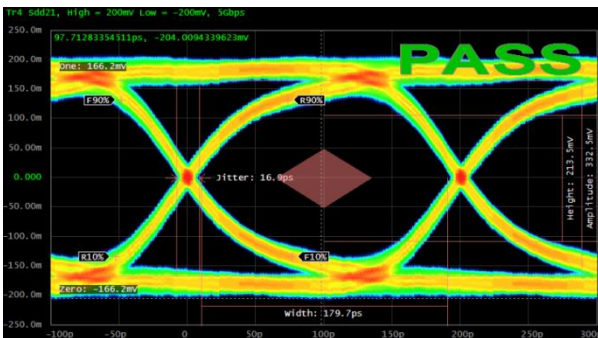

**USB3.0 Mask at 5.0 Gb/s
with UESD**

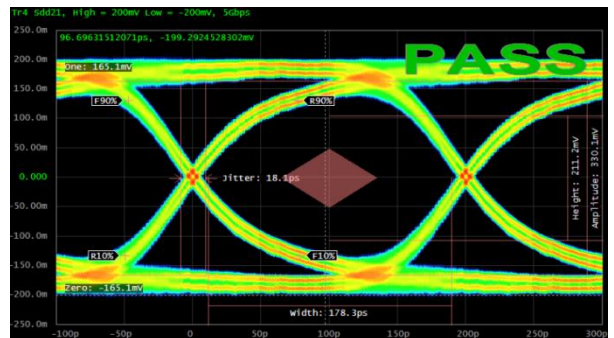

ESD Protection for HDMI

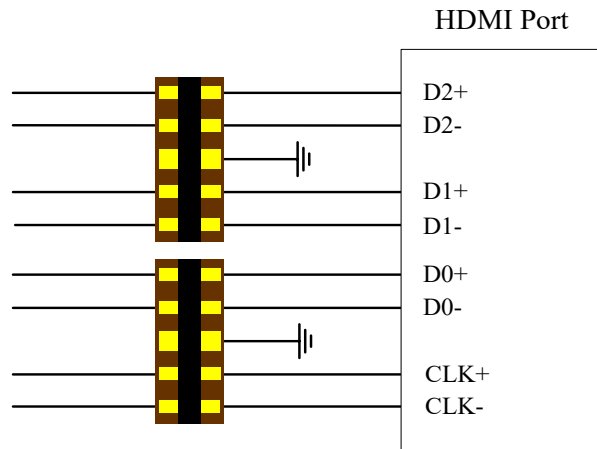

ESD Protection for USB 3.0 Type A

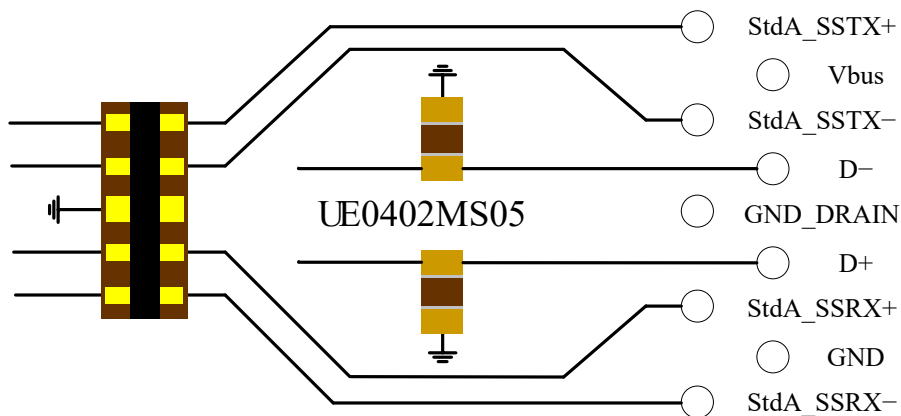

ESD Protection for eSATA

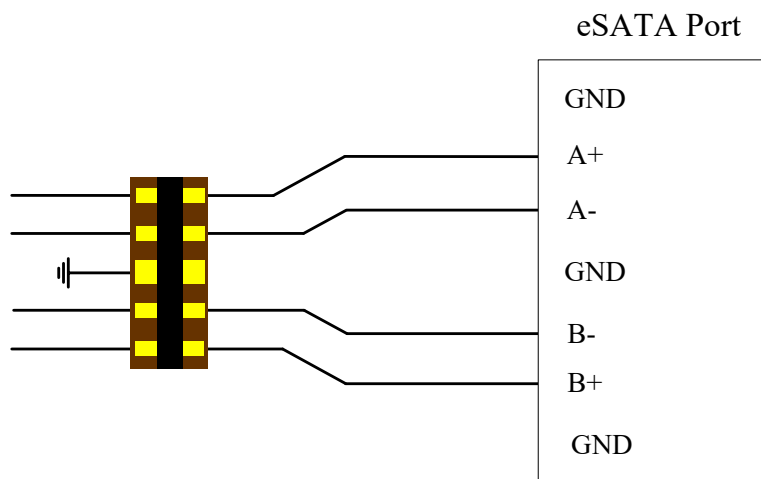

Package Dimension

Package outline

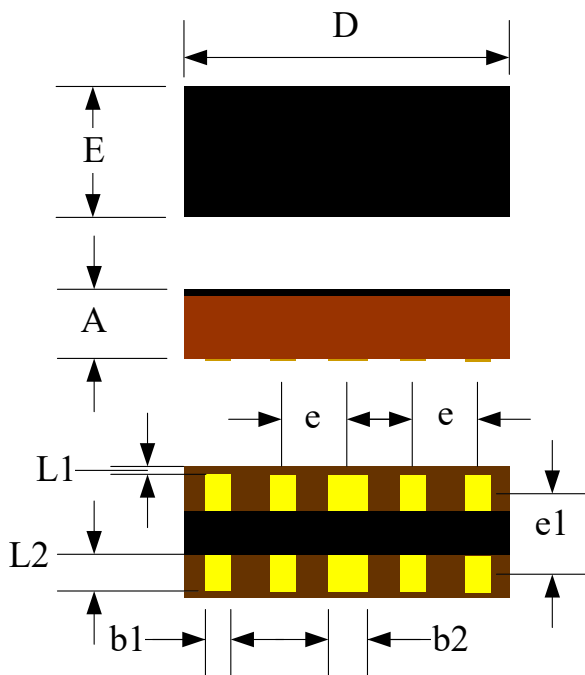

Recommended Solder Pad Footprint

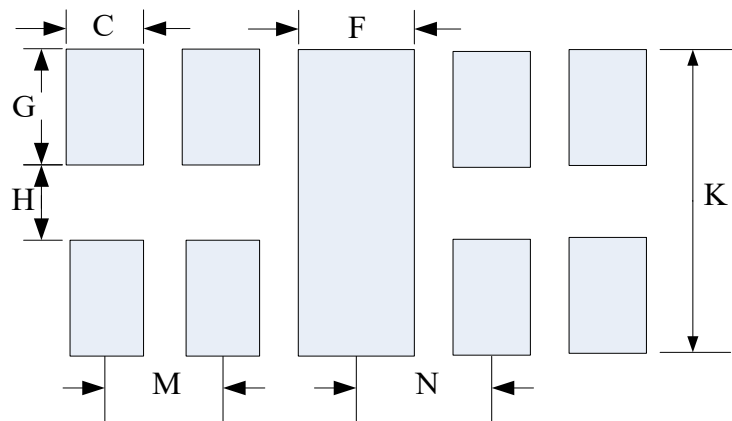

Dimension	Unit: Millimeters		
	Min.	Typ.	Max.
A	0.40	0.50	0.60
b1	0.10	0.20	0.30
b2	0.20	0.30	0.40
D	2.40	2.50	2.60
E	0.90	1.00	1.10
e	0.40	0.50	0.60
e1	0.50	0.60	0.70
L1	0.04	0.05	0.06
L2	0.20	0.30	0.40

Dimension	Unit: Millimeters		
	Min.	Typ.	Max.
C	0.20	0.25	0.30
F	0.35	0.40	0.45
G	0.55	0.60	0.65
H	0.25	0.30	0.35
K	1.40	1.50	1.60
M	0.45	0.50	0.55
N	0.45	0.50	0.55

Taping Specification

1. Tape Dimension

Unit: Millimeters

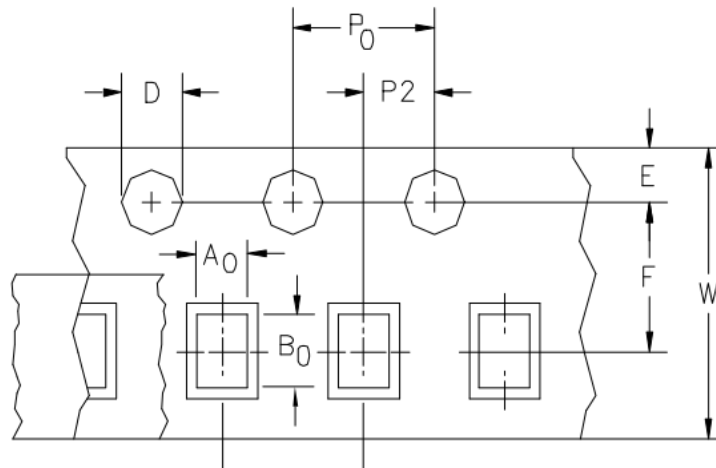

P ₀	P ₂	D	B ₀	A ₀	E	F	W
4.00±0.10	2.00±0.05	∅1.50±0.10	2.70±0.05	1.23±0.05	1.75±0.10	3.50±0.05	8.00±0.30

2. Reel Dimension

Unit: Millimeters

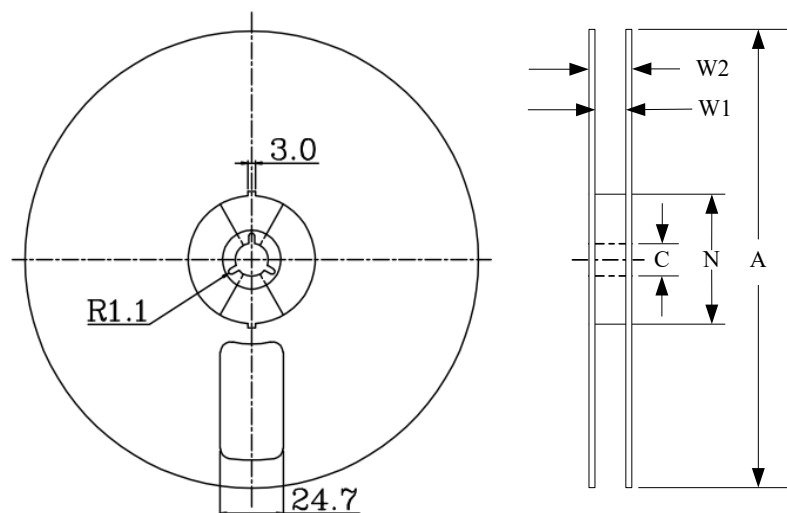

A	N Min.	C	W ₂ Max.	W ₁ Min.	W ₁ Max.	Quantity
178.0 ±2.0	50.0	13.0±0.2	14.4	8.4	9.9	3000 EA

Part Numbering

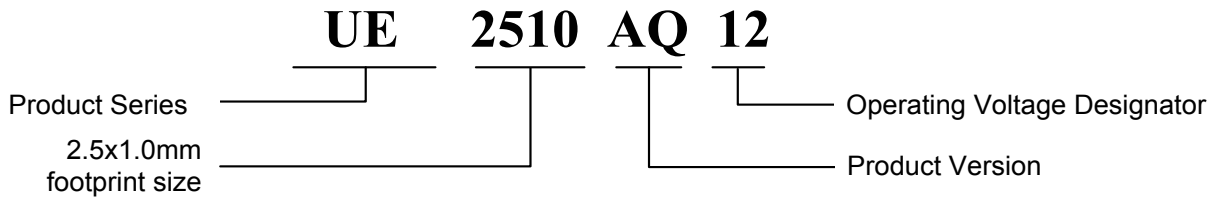

Soldering Parameters

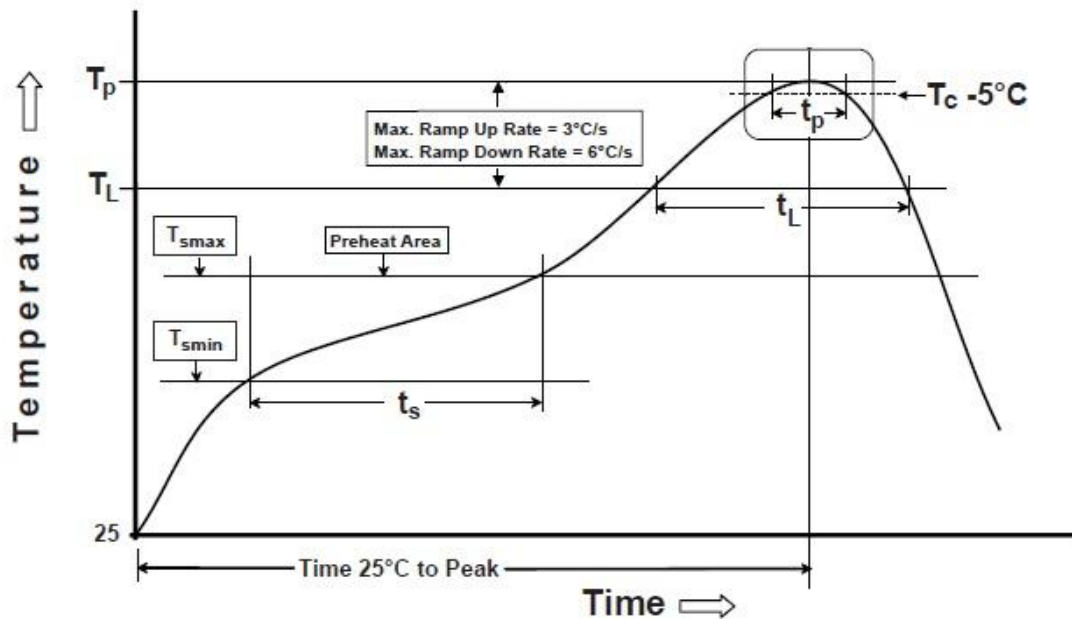

Profile Feature	Pb-Free Assembly
Pre Heat	
Temperature Min (T_{smin})	150 °C
Temperature Max (T_{smax})	200 °C
Time (t_s) from (T_{smin} to T_{smax})	60-120 seconds
Ramp-up Rate (T_L to T_p)	3 °C/second max.
Liquidus temperature (T_L)	217 °C
Time (t_L) maintained above T_L	60-150 seconds
Peak package body temperature (T_p)	260 ^{+0/-5} °C
Time (t_p)* within 5 °C of the specified classification temperature (T_c)	30* seconds
Ramp-down Rate (T_p to T_L)	6 °C/second max.
Time 25 °C to peak temperature	8 minutes max.
* Tolerance for peak profile temperature (T_p) is defined as a supplier minimum and a user maximum.	